

# MORISSET

## STREETSCAPE TECHNICAL GUIDELINES



### Revision History

Streetscape Technical Guidelines - Morisset			
Rev No.	Date Changed	Modified by	Details / Comments
01	15 June 2018	CSC	Finalised for publishing on LMCC website.

### Disclaimer

Check the Currency of the Morisset Streetscape Technical Guidelines in association with the Morisset Streetscape Master Plan

Check the Currency of all cross-referenced documents such as Guidelines, Australian Standards, Standards, Standard Details, and Standard Drawings

## Contents

<b>1.0 PURPOSE OF THIS DOCUMENT</b> .....	<b>3</b>
<b>2.0 PLANNING CONTEXT</b> .....	<b>4</b>
<b>3.0 HOW TO USE THIS DOCUMENT</b> .....	<b>5</b>
<b>4.0 DESIGN DOCUMENTATION</b> .....	<b>6</b>
CONSULTANT REQUIREMENTS .....	6
DESIGN DETAILING .....	6
COMPLIANCE WITH COUNCIL'S STANDARD DRAWINGS .....	6
SURVEY DOCUMENTATION .....	6
<b>5.0 CONSTRUCTION MANAGEMENT</b> .....	<b>7</b>
HOLD POINTS, INSPECTIONS AND SUBMISSIONS .....	7
PRACTICAL COMPLETION .....	7
DEFECTS LIABILITY AND MAINTENANCE .....	7
ASSET HANDOVER .....	8
<b>6.0 SPECIFICATION GUIDANCE FOR SITE ESTABLISHMENT AND PRELIMINARIES</b> .....	<b>9</b>
CONSTRUCTION IN THE PUBLIC DOMAIN.....	9
PROTECTION- EXISTING TREES.....	10
<b>7.0 MATRIX OF ELEMENTS</b> .....	<b>11</b>
<b>8.0 PAVING</b> .....	<b>12</b>
8.1 PAVER – CONCRETE SEGMENTAL.....	13
8.2 TACTILE GROUND SURFACE INDICATORS (TGSi) .....	14
8.3 CONCRETE PAVEMENT – STANDARD .....	15
8.4 CONCRETE PAVEMENT – COLOURED .....	15
8.5 COBBLE SETTS .....	16
8.6 PERMEABLE PAVERS .....	17
<b>9.0 PLANTING</b> .....	<b>18</b>
9.1 TREE IN ROAD.....	19
9.2 TREE IN FOOTPATH.....	19
9.3 TREE IN TURF VERGE.....	19
9.4 TURF .....	20
9.5 MASS PLANTING .....	20
9.6 TREE GUARD .....	21
<b>10.0 LIGHT POLES</b> .....	<b>22</b>
10.1 STREET LIGHTING.....	23
10.2 PEDESTRIAN LIGHTING .....	23
<b>11.0 FURNITURE</b> .....	<b>24</b>
11.1 BIKE RACKS.....	25
11.2 BOLLARD - STANDARD.....	26
11.3 DRINKING FOUNTAINS .....	27
11.4 WASTE RECEPTACLES .....	28
11.5 SEAT – STANDARD .....	29
11.6 SEAT – CUSTOM.....	29
<b>12.0 MORISSET CUSTOM DETAILS</b> .....	<b>30</b>

## 1.0 Purpose of this document

To help ensure that development activity results in the community obtaining public benefit, developers are required to undertake public domain improvements in association with their developments. Lake Macquarie City Council has developed Streetscape Master Plans to illustrate requirements for public domain works within the City's Town Centres.

The Streetscape Master Plans provide site analysis and contextual information to assist designers prepare detailed site plans for the public domain. This document provides detailed technical information and specifications to assist in the preparation of design and construction documentation for public domain works.

These Guidelines are applicable to the extents shown in the Streetscape Master Plan applicable to the relevant town centre. Heritage areas and precincts have their own distinct character derived from their unique history. Selections and treatments contained in these Guidelines are not applicable to heritage areas, seek guidance from Council's Development Planner – Heritage Focus where streetscape works are proposed in areas identified as Heritage Conservation Areas and Heritage Precincts.

Designers should also refer to Lake Macquarie City Council's Engineering Guidelines and Landscape Design Guidelines to ensure designs and documentation are prepared to Council's standards.

The Streetscape Technical Guidelines aim to:

- Ensure public domain treatments are consistent with the adopted Master Plan design concepts for each Town Centre;
- Ensure assets in the public domain are of a suitable quality.

## 2.0 Planning Context

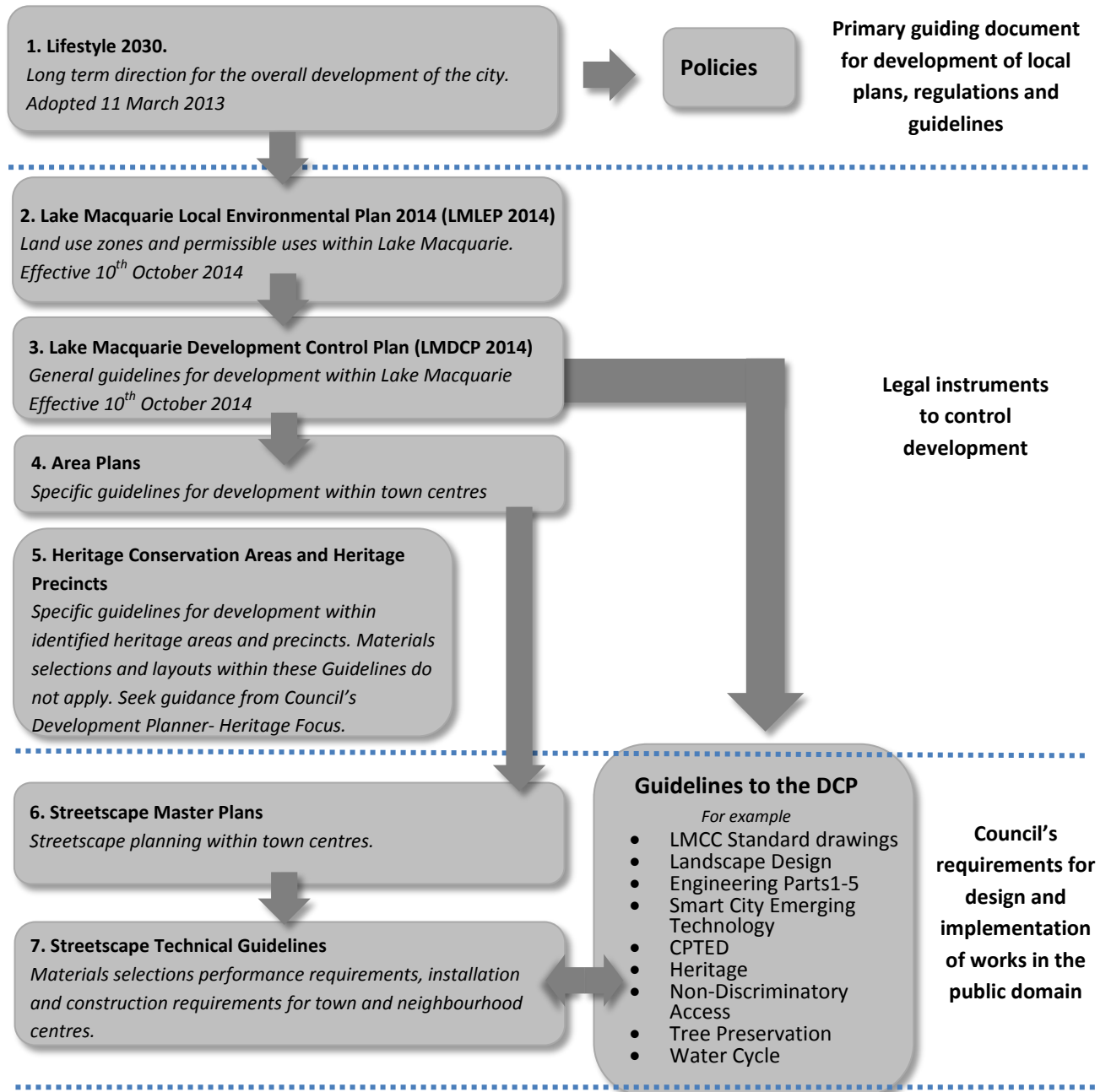

## 3.0 How to use this document

Read this document in conjunction with the Streetscape Master Plan relevant to the development site.

This document may also direct designers and specifiers to other Council Guidelines, Policies and Standard Drawings. All referenced documents are available on Council's website or through contacting Councils Development Planners.

Failure to meet the requirements outlined in both the Streetscape Master Plans and associated Technical Guidelines may result in works being rejected by Council.

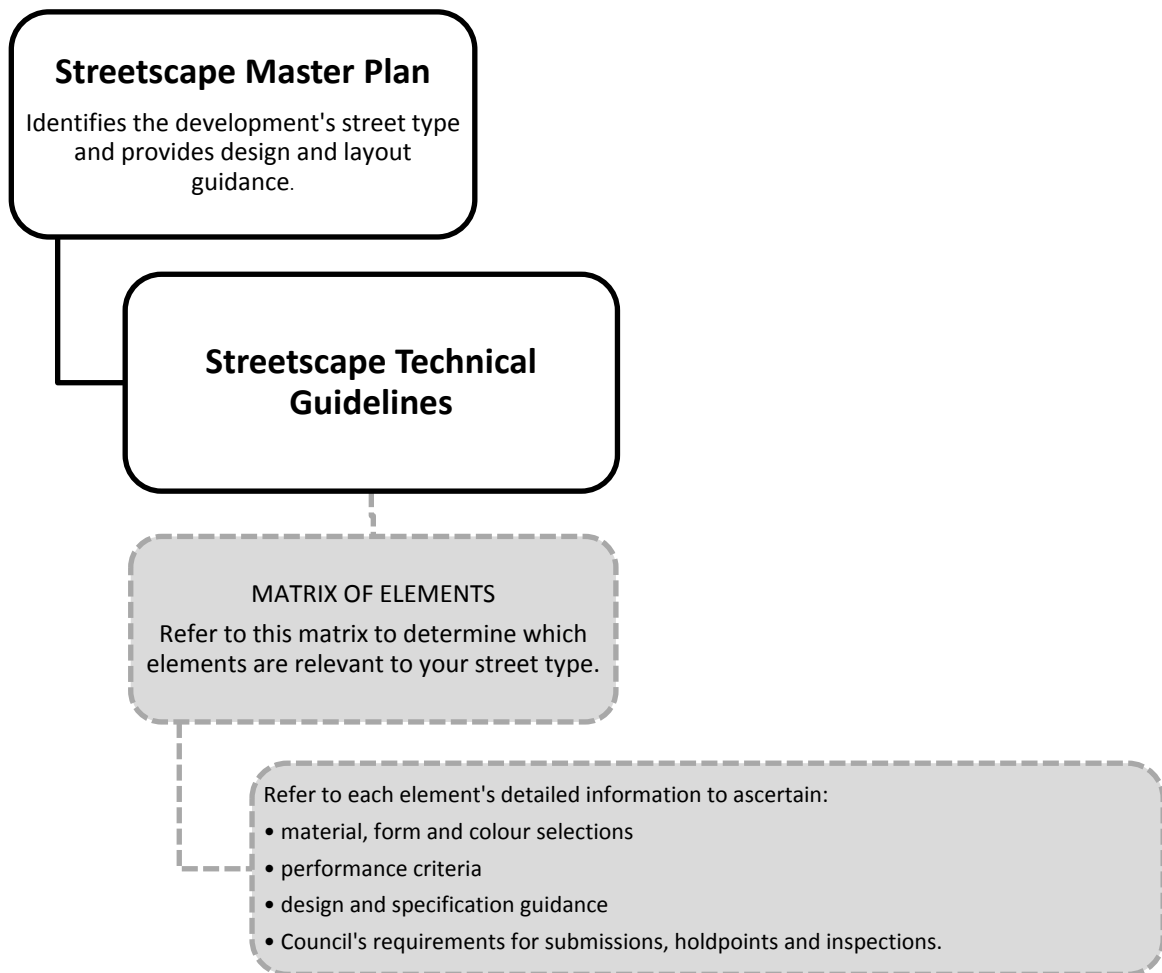

### 4.0 Design Documentation

#### Consultant Requirements

Lake Macquarie Development Control Plan (LMDCP) 2014 outlines consultant and documentation requirements for landscape design relevant to each land use zone. Public domain and high profile locations such as town centres are classed as Landscape Category 3 development and landscape documentation must be undertaken by a qualified and experienced Landscape Architect. The Landscape Design Guidelines provide further requirements for development classed as Landscape Category 3.

Landscape design shall be supported by the engagement of suitably qualified and experienced engineers to carry out structural and civil detailing. All documentation shall be fully coordinated and integrated with the building design.

#### Design detailing

This guideline provides information about typical treatments only. Additional site-specific design detailing is required to resolve the unique circumstances of each site. The designer is responsible for checking and customising all detailing and specifications to ensure relevance for the specific site context.

#### Compliance with Council's Standard Drawings

Council has developed a set of standard details that describe the minimum requirements for works within the public domain. The Streetscape Technical Guidelines may reference these standard details, however it is the designer's responsibility to ensure that all construction details are adapted to suit specific site and project requirements.

Council's standard details are available from council's website under the Development Control Plan (DCP) Landscape and Engineering Guidelines:

- Roadway standard drawings
- Drainage standard drawings
- Landscape standard drawings
- Miscellaneous standard drawings

#### Survey documentation

Numerous Survey Marks may exist within town centres, such as Permanent or State Survey Marks (SSMs), buried reference marks and kerb drill hole and wings. These must be located by a Registered Surveyor prior to being destroyed or covered and must be maintained in accordance with the requirements of NSW Department of Land and Property.

Prior to the commencement of any works affecting survey marks, a "Plan of Survey Information" is required to be prepared by a Registered Surveyor and lodged at the NSW Department of Land and Property Information.

Note: The *Surveying Act 2002* prescribes penalties for disturbance or removal of permanent or state survey marks.

### 5.0 Construction Management

These Streetscape Technical Guidelines require developers, consultants and contractors to undertake inspections with a representative of Council and to provide submissions to such representatives.

Nominated hold points, inspections and submissions must be included in the design and construction documentation for all works in the public domain. Inclusion of such measures in these guidelines, and incorporating them into project specific documentation, allows developers, consultants and contractors to:

- recognise Council's expectations and requirements;
- budget and program such requirements at project initiation.

#### **Hold points, inspections and submissions**

Hold points, inspections and submissions enable Council to be certain that public domain assets meet the quality specified in the approved documentation, and that such assets are installed to meet the performance requirements specified in approved documentation.

Hold points and inspections may occur during set-out of streetscape items, during excavation and footing pours, and prior to the installation of items.

Submissions may include warranties on proprietary components, certifications that items meet required standards, and reporting on maintenance, defects and replacements and rectification works.

#### **Practical Completion**

For works installed in the public domain, submission of a Landscape Compliance Report may be requested. Such inspections and reporting is critical to outline any minor defects, which must be rectified, and any specific landscape maintenance requirements during the maintenance period.

For detailed information and checklists relevant to compliance of streetscape elements at practical completion, refer to the Landscape Design Guidelines.

#### **Defects Liability and Maintenance**

After practical completion, a Landscape Rectification Report may be requested to ensure that any necessary works identified in the Landscape Compliance Report have been carried out and to provide evidence that an appropriate level of landscape maintenance is being performed.

For detailed information and checklists relevant to compliance of streetscape elements during the Defects and Liability and Plant Establishment periods, refer to the Landscape Design Guidelines.

### **Asset Handover**

For works installed in the public domain, a site inspection with a representative of Council is required prior to Council accepting responsibility of the assets. Submission of a Handover Report may also be requested.

Such inspections and reporting are critical to:

- Enable Developers, Consultants and Contractors to evidence they have met the approved documented requirements agreed on through the development consent process;
- Prevent Council from having to divert resources to rectify or unreasonably maintain poorly selected and installed assets.

For detailed information and checklists relevant to Asset Handover of streetscape elements, refer to the Landscape Design Guidelines.



## 6.0 Specification Guidance for Site Establishment and Preliminaries

### Construction in the Public domain

<b>Location</b>	To all public domain works located within the boundaries of Council's Streetscape Master Plans and subject to these Technical Guidelines.
<b>Positioning</b>	Confine all works within the defined and approved site boundaries.
<b>Access</b>	
Pedestrian Control	<ul style="list-style-type: none"> <li>• Ensure that appropriate barriers, signage and pedestrian safety measures are put in place before work commences.</li> <li>• Where public access is diverted, temporary ramps and walkways must be installed with compliance to relevant safety standards.</li> </ul>
Construction Traffic Control	<ul style="list-style-type: none"> <li>• Manage all site deliveries and subcontractors vehicles during construction to avoid damage to finished pavements, planting and installed furniture items.</li> <li>• Ensure there are no vehicle movements on finished pavements not designed for vehicle loadings.</li> <li>• All traffic management shall be undertaken in accordance with AS1742.3 and the the RMS Traffic Control at Worksites Manual (the Manual). This Manual contains standard TCPs for a variety of situations. Where a standard TCP is not suitable, a 'site-specific' TCP shall be developed and implemented in accordance with the Manual.</li> </ul>
<b>Environmental Sustainability</b>	Council is committed to making Lake Macquarie a sustainable city with healthy ecosystems. Construction works in the public domain can support this commitment with the following measures.
Erosion and Sediment Control	<ul style="list-style-type: none"> <li>• Erosion and sediment Control (ESC) measures must be in place prior to the commencement of works.</li> <li>• ESC measures must be in accordance with approved plans and planning consents.</li> <li>• Where works have planning approval under State Environmental Planning Policy- Infrastructure, ESC measures must be in accordance with the 'Blue Book'. Refer all queries to Councils Erosion and Sediment Control officer.</li> </ul>
Nuisance	<ul style="list-style-type: none"> <li>• Adhere to specified approved work hours.</li> <li>• Prevent undue noise or light spill from construction activity.</li> </ul>
Soil contamination	Contaminated or potentially contaminated land should be managed in accordance with the NSW Contaminated Land Management Act (1997), State Environmental Planning Policy (SEPP) 55- Remediation of Land and associated guidelines and Lake Macquarie City Council's Procedure - Management of Contaminated or Potentially Contaminated Land where soil contaminants are reasonably suspected to be present or are uncovered through the course of works on public land under Council's care and control.
Waste	<ul style="list-style-type: none"> <li>• All construction waste must be removed on completion of works, and disposed of at a licensed waste facility.</li> <li>• Make good site as soon as practicable.</li> </ul>
<b>Performance Criteria</b>	
Quality Assurance	<ul style="list-style-type: none"> <li>• All works in the public domain will be carried out in accordance with approved project plans and planning consents.</li> <li>• The most current version of approved plans must be available on site for reference during work hours.</li> <li>• All substitutions shall be approved by Council's Project Manager prior to ordering. Provide adequate notice to maintain the option of rejecting substitution proposals.</li> <li>• All works shall be undertaken/supervised by contractors holding a current endorsed individual contractor licence or qualified supervisor certificate relevant to the class of work being undertaken.</li> </ul>
Vegetation Protection	<ul style="list-style-type: none"> <li>• All vegetation to be retained must be protected in accordance with AS4970 Protection of Trees on Development Sites.</li> <li>• All pruning works to comply with AS4373 Pruning of Amenity Trees.</li> <li>• See <b>Protection – Existing Trees</b> for detailed guidance.</li> </ul>
Work, health and Safety	Processes and procedures compliant with the WHS Act 2011 must be in place for managing site safety.
Utilities and existing infrastructure	<ul style="list-style-type: none"> <li>• Confirm and record location of all services on site prior to commencement of works.</li> <li>• Current Dial Before You Dig plans to be retained on site at all times.</li> <li>• Mark and record all parking and regulatory signage to ensure signs are correctly re-instated on completion of works.</li> </ul>
<b>Installation</b>	
Site Protection	Take all precautions to protect adjacent property, structures and vegetation from damage during construction.
Notification - Hold points and submissions	<ul style="list-style-type: none"> <li>• Contact Council's nominated Project Officer to undertake inspections and receive submissions specified for each streetscape element in these guidelines, and as noted on Council's relevant Standard Drawings.</li> <li>• Provide sufficient notice to allow the nominated Council Project Officer to attend all specified inspections prior to executing the works, and to review all supplied submissions prior to placing orders and executing the works.</li> </ul>
<b>Relevant Standards and Codes</b>	<ul style="list-style-type: none"> <li>• NSW Work Health and Safety Act 2011</li> <li>• AS4970 Protection of Trees</li> <li>• AS4373 Pruning of Amenity Trees</li> <li>• Lake Macquarie City Council's Engineering Guidelines – Part 2 - Construction</li> <li>• Lake Macquarie City Council's Erosion Prevention and Sediment Control Guideline</li> <li>• Landcom's 'Blue Book' (Managing Urban Stormwater Soils and Construction)</li> <li>• Lake Macquarie City Council Noise Control Policy</li> <li>• NSW Protection of the Environment Operations Act 1997</li> <li>• Lake Macquarie City Council's Environmental Management Plan for Contaminated Land in Council's Care and Control - Procedure</li> <li>• AS1742.3 Traffic Control devices for Works on roads</li> </ul>

**Protection- Existing Trees**

<b>Location</b>	<ul style="list-style-type: none"> <li>To all instances where existing trees are required or desired to be retained, including trees on neighbouring land where works will have an impact.</li> </ul>
<b>Positioning</b>	<ul style="list-style-type: none"> <li>The extent of the Tree Protection Zone (TPZ) is to be determined by the project Arborist in accordance with AS4970.</li> <li>AS4970 provides a calculation for determining the required TPZ, and also requires a TPZ should not be less than 2m nor greater than 15m (except where crown protection is required).</li> </ul>
<b>Equal Access</b>	<ul style="list-style-type: none"> <li>Retained trees shall not encroach into accessible paths of travel. If required, trees must be pruned to ensure that a vertical clearance of 2000mm is maintained along all accessible paths of travel 2000mm in accordance with AS1428.1. and AS1428.2</li> </ul>
<b>Environmental Sustainability</b>	<ul style="list-style-type: none"> <li>The retention of established trees is an objective for development in both Business and Residential zones under the <i>LMCC DCP2014</i> . Established trees with a sound structure provide many ecosystem benefits including urban amenity, microclimate, scenic quality, air and water quality, wildlife habitat, wind protection and social and psychological values. Retention of trees can significantly enhance new development by immediately providing the above mentioned benefits.</li> </ul>
<b>Performance Criteria</b>	<ul style="list-style-type: none"> <li>All protection measures shall be in accordance with the approved development plans prepared by a Level 5 consulting Arborist, and in accordance with AS4970 Protection of trees on construction sites.</li> <li>Install protection measures at site establishment phase and prior to any machinery or materials arriving on site.</li> <li>Tree Protection Zones (TPZs) are to be enclosed by fencing with signage in accordance with AS4970 to advise site workers that the area is a tree protection zone.</li> <li>Tree protection measures are to remain in place for the duration of the works, with selective protective measure removed as necessary to complete the works.</li> <li>Where access is required within the TPZ, undertake protective measures in accordance with AS4970 to provide protection from : <ul style="list-style-type: none"> <li>Compaction and excavation of tree root systems</li> <li>Mechanical damage to the tree trunk and canopy</li> </ul> </li> <li>All works undertaken within the TPZ shall be supervised by the project Arborist.</li> </ul>
<b>Installation</b>	<ul style="list-style-type: none"> <li>Conduct a pre-construction meeting to introduce tree protection measure requirements to site managers and contractors.</li> <li>Tree protection measures, fencing and signage to be installed in accordance with AS4970 and project specific Tree Protection plans (if applicable) prior to construction works commencing.</li> </ul>
<b>Quality Assurance</b>	<ul style="list-style-type: none"> <li>All tree removal and pruning works are to be carried out by suitably qualified Level 3 Arborist.</li> <li>A suitably qualified Level 3 Arborist shall be appointed to supervise: <ul style="list-style-type: none"> <li>the installation of all protection measures;</li> <li>all works undertaken within the TPZ.</li> </ul> </li> </ul>
<b>Relevant Standards and Codes</b>	<ul style="list-style-type: none"> <li>AS4970 Protection of trees on construction sites</li> <li>AS4373 Pruning of amenity trees</li> <li>AS1428 Design for Access and Mobility Suite</li> </ul>
<b>Standard Drawing Reference</b>	<ul style="list-style-type: none"> <li>LSD-SPEC-01 Typical Tree Planting</li> </ul>
<b>Practical Completion</b>	<ul style="list-style-type: none"> <li>A Level 5 Consulting Arborist shall be appointed to assess all retained trees and report recommendations for any remedial actions required.</li> </ul>
<b>Maintenance and Establishment</b>	<ul style="list-style-type: none"> <li>The TPZ shall be maintained by mulching, watering and weed removal in accordance with AS4970.</li> <li>The project Arborist shall inspect and certify that all remedial works identified at practical completion have been undertaken.</li> </ul>
<b>Asset handover</b>	<ul style="list-style-type: none"> <li>A copy of the Arborists reports from Practical Completion and Rectification/Remedial works certifications shall be supplied to Council's representative at Asset Handover stage.</li> </ul>

## 7.0 Matrix of Elements

Element	Street Type A	Street Type B	Street Type C	Street Type D	Street Type E	Street Type F
<b>Pavement</b>						
Paver – Concrete Segmental	X					X
Tactile Ground Surface Indicator (TGSi)	X	X	X	X	X	X
Concrete pavement - Coloured	X	X	X	X		X
Concrete pavement - Standard		X	X	X	X	
Paver – Cobble setts	X	X	X	X		X
Paver - Permeable		X	X	X		X
<b>Planting</b>						
Trees - in road		X	X	X		X
Trees – on footpath	X					
Trees – in turf verge			X	X		
Mass planting	X	X	X	X		X
Tree Guard – standard (+IP) – (Morisset feature infill panel)	X (+ IP)	X	X	X		X (+ IP)
<b>Lighting</b>						
Street lighting	Need for the installation of new lights to be determined through the development approval process					
Pedestrian lighting						
Awning lighting						
<b>Furniture</b>						
Bike Rack – single loop	X	X	X	X		X
Bollard	X	X	X	X		X
Drinking Fountain	X	X		X		X
Waste Receptacles (Bin)	X	X	X	X		X
Seat – Standard (back + armrests)	X	X	X	X		X
Seat - Morisset custom seat	X					X

## 8.0 Paving

<b>8.1 Paver – Concrete Segmental</b>	<b>13</b>
<b>8.2 Tactile Ground Surface Indicators</b>	<b>14</b>
<b>8.3 Concrete Pavement – Standard</b>	<b>15</b>
<b>8.4 Concrete Pavement - Coloured</b>	<b>15</b>
<b>8.5 Paver - Cobble Setts</b>	<b>16</b>
<b>8.6 Paver - Permeable</b>	<b>17</b>

## 8.1 Paver – Concrete Segmental



<b>Laying Pattern</b>	As noted in the Morisset Streetscape Master Plan
<b>Paver Colour</b>	A neutral ivory coloured paver with white, brown and grey aggregate equal to the Council approved existing installation on Station Street.  <b>Submit a sample of proposed paving for approval by Council's nominated project officer prior to ordering project quantities. Lead times will apply – check with suppliers.</b>
<b>Paver Finish</b>	Honed with a light shot blast over to expose paver aggregate, and meet slip resistance requirements.
<b>Paver Dimension</b>	Nom. 400x400mm
<b>Paver Thickness</b>	Nominal 55mm for pedestrian and light vehicle loading.
<b>Standard Drawing Reference</b>	<ul style="list-style-type: none"> <li>•LSD-PAV-01- Paver – Large format (for town centres)</li> <li>•LSD-PAV-02- Concrete footpaths – full width, with banding and header (for town centres)</li> </ul>

## Pavers- Guidance on design and specifying

<b>Positioning</b> Set-out to furniture and in-ground fixtures	<ul style="list-style-type: none"> <li>• Generally continue pavers under surface mounted furniture items and cut pavers to finish up to the base of in-ground fixtures such as street signs, planter boxes and walls.</li> <li>• Provide a 10mm mastic expansion joint around in-ground fixtures.</li> </ul>																		
<b>Equal Access</b>	<ul style="list-style-type: none"> <li>• Cross falls shall be 1:40, consistent with AS1428.1</li> <li>• Ensure flush transitions between adjoining pavers and other surfaces.</li> </ul>																		
<b>Environmental Sustainability</b>	<ul style="list-style-type: none"> <li>• Street pavements occupy a large part of a town centres area, providing significant opportunities to contribute to sustainability outcomes. These paver specifications maximise durability to ensure a long service life with low maintenance requirements, therefore minimising the need to replace or re-instate pavements.</li> <li>• Where appropriate, design pavement gradients to allow surface water to flow to mass planting, turf and tree pits.</li> </ul>																		
<b>Paver Performance Criteria</b> Quality Assurance	<ul style="list-style-type: none"> <li>• Pavers supplied shall be consistent with one another and samples.</li> <li>• Submit the following details to Council's nominated Project Officer: <ul style="list-style-type: none"> <li>- details of the proposed paver supplier and a sample of each paver proposed for use.</li> <li>- Confirmation from supplier that the proposed pavers comply with the Performance Criteria specified in these guidelines, including slip resistance test results.</li> </ul> </li> </ul>																		
Traffic Loads	<p>Pavement design must be suitable for the expected traffic loads in relation to both strength and abrasion resistance. Definitions of Light vehicles and Commercial vehicles are in accordance with the <i>CMAA Concrete Flag Pavement Design and Construction Guide</i> as follows:</p> <ul style="list-style-type: none"> <li>• Light vehicles - vehicles that have a fully loaded weight less than 3 tonnes. As a minimum all town centre pavements and residential driveways are required to carry these loads.</li> <li>• Commercial vehicles - vehicles that have a gross weight of 3 tonnes or more. This category of pavement includes commercial driveways, footpaths subject to truck overrun or parking, pedestrian malls accepting service vehicles and lightly trafficked streets.</li> </ul>																		
Pavement application:	<table border="1"> <thead> <tr> <th></th> <th>Nom. Size (mm)</th> <th>Minimum thickness (mm)</th> <th>Characteristic breaking load (kN) when tested in accordance with AS 4456.5</th> </tr> </thead> <tbody> <tr> <td>Pedestrian and Light vehicles</td> <td>Any up to 450 x 450</td> <td>50</td> <td>7.0</td> </tr> <tr> <td rowspan="3">Pedestrian/Commercial vehicles</td> <td>300 x 300</td> <td>60</td> <td>13.8</td> </tr> <tr> <td>400 x 400</td> <td>65</td> <td>15.5</td> </tr> <tr> <td>450 x 450</td> <td>70</td> <td>18.8</td> </tr> </tbody> </table>		Nom. Size (mm)	Minimum thickness (mm)	Characteristic breaking load (kN) when tested in accordance with AS 4456.5	Pedestrian and Light vehicles	Any up to 450 x 450	50	7.0	Pedestrian/Commercial vehicles	300 x 300	60	13.8	400 x 400	65	15.5	450 x 450	70	18.8
	Nom. Size (mm)	Minimum thickness (mm)	Characteristic breaking load (kN) when tested in accordance with AS 4456.5																
Pedestrian and Light vehicles	Any up to 450 x 450	50	7.0																
Pedestrian/Commercial vehicles	300 x 300	60	13.8																
	400 x 400	65	15.5																
	450 x 450	70	18.8																
Slip Resistance -External walkways:	<ul style="list-style-type: none"> <li>• P4 when tested in accordance with the wet pendulum test methods outlined in AS4586.</li> <li>• R10 when tested in accordance with the oil-wet inclining platform test outlined in AS4586.</li> </ul>																		
- External ramps:	<ul style="list-style-type: none"> <li>• P5 when tested in accordance with the wet pendulum test methods outlined in AS4586.</li> <li>• R11 when tested in accordance with the oil-wet inclining platform test outlined in AS4586.</li> </ul>																		
Potential to effloresce	Nil to slight when tested in accordance with AS4456.6																		
Mean Abrasion resistance	3.5 when tested in accordance with AS4456.9																		
Allowable Dimensional Deviations	<ul style="list-style-type: none"> <li>• Mean allowable dimensional deviation is +/- 1.5mm (plan) and +/- 2mm (height).</li> <li>• The pavers shall be sufficiently flat to enable the units to be laid in a pavement to give a functional and aesthetically acceptable surface.</li> </ul>																		
<b>Installation</b> Quality Assurance	<p>In accordance with the referenced Landscape Standard Drawings.</p> <ul style="list-style-type: none"> <li>• Submissions: The following must be submitted to Council's nominated Project Officer prior to execution of the paving works: <ul style="list-style-type: none"> <li>- Contractor's licences in accordance with Paving Contractor Requirements below;</li> <li>- Confirmation that a 'Plan of Survey Information' has been submitted to the NSW Dept. of Land and Property Information.</li> <li>- Samples of proposed pavers for approval by Council's nominated Project Officer prior to ordering project quantities.</li> </ul> </li> <li>• Inspections: Council's nominated Project Officer is to carry out the following inspections: <ul style="list-style-type: none"> <li>- Sub-grade and sub-base prior to concrete slab being installed;</li> <li>- Reinforcement in place ready for concrete pour;</li> <li>- Concrete slab ready for laying;</li> <li>- Commencement of segmental paving;</li> <li>- Completion of segmental paving.</li> </ul> </li> <li>• Paving Contractor Requirements: All paving work shall be undertaken/supervised by a Contractor with a current NSW Dept. of Fair Trading endorsed license in any of the following classes- Building, Structural Landscaping or Minor Trade-Paving.</li> </ul>																		
Tolerances	Maximum tolerance for deviations between adjoining pavers and with other surfaces shall be 2.5mm with a flatness deviation of 3mm using a 3m straight edge.																		
Repairs	Repair broken pavers immediately.																		
Protection of surfaces	Ensure adequate protection of finished surfaces during remaining completion of works.																		
<b>Relevant Standards and Codes</b>	<ul style="list-style-type: none"> <li>• AS1428 Design for Access and Mobility Suite</li> <li>• AS4456 Masonry units and segmental pavers and flags Suite</li> <li>• AS4586 Slip resistance classification of new pedestrian surface materials</li> </ul>																		
<b>Warranties</b>	Supply a warranty with Lake Macquarie City Council nominated as the warrantee for works in the public domain.																		



## 8.2 Tactile Ground Surface Indicators (TGSIs)

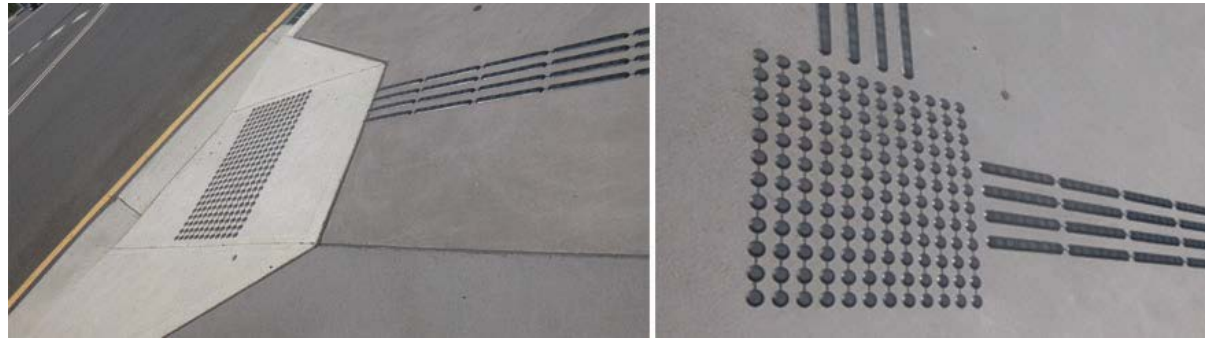

Example of bladed tactile ground surface indicators.

<b>Location</b>	In accordance with AS1428 to all street types
<b>Type</b>	Bladed-shaft hazard system
<b>Material</b>	Thermoplastic Polyurethane
<b>Unit Dimensions</b>	300mm/600mm strips x min. 10mm deep shaft
<b>Colour</b>	Black Ensure luminance contrast requirements with surrounding ground plane are achieved.
<b>Standard Drawing Reference</b>	N/A – refer to manufacturer’s installation details

## Tactile Ground Surface Indicators (TGSIs) – Guidance on design and specifying

<b>Positioning</b>	Position in accordance with AS1428.4.1.- Tactile Ground Surface Indicators
<b>Equal Access</b>	<ul style="list-style-type: none"> <li>Tactile indicators provide blind or vision impaired people with information to help navigate footpaths, large open pedestrian spaces and cross roads. TGSIs systems are comprised of two types: <ul style="list-style-type: none"> <li>Hazard or warning indicators to alert potential danger;</li> <li>Directional indicators to give directional orientation in open spaces where there are insufficient tactile directional cues (e.g., handrails or walls); to designate the route to avoid a hazard in the absence of existing tactile cues; and to give directional orientation where a person must deviate from the regular continuous accessible path of travel.</li> </ul> </li> <li>Do not install TGSIs unnecessarily, as they will not compensate for poor design. Good design practice (designing for clear paths of travel with delineated edges) should minimize the need for TGSIs.</li> </ul>
<b>Environmental Sustainability</b>	Street pavements occupy a large part of a town centres area, providing significant opportunities to contribute to sustainability outcomes. The TGSIs specifications within these Technical Guidelines maximise durability to ensure a long service life with low maintenance requirements, therefore minimising the need to replace or re-instate the indicators.
<b>Performance Criteria</b>	<ul style="list-style-type: none"> <li>Design and arrangement of TGSIs must comply with AS1428.4.1.</li> <li>TGSIs must be constructed from robust vandal and corrosion resistant materials.</li> <li>TGSIs must be securely installed to prevent trip hazards, unauthorised removal or accidental removal by street-sweeping mechanical plant. .</li> </ul>
<b>Colour Contrast</b>	<ul style="list-style-type: none"> <li>Colour selections must match the luminance contrast against background and surrounding ground plane materials in accordance with AS1428.4</li> </ul>
<b>Slip Resistance -External walkways:</b>	<ul style="list-style-type: none"> <li>P4 when tested in accordance with the wet pendulum test methods outlined in AS4586.</li> <li>R10 when tested in accordance with the oil-wet inclining platform test outlined in AS4586.</li> </ul>
<b>Slip Resistance - External ramps:</b>	<ul style="list-style-type: none"> <li>P5 when tested in accordance with the wet pendulum test methods outlined in AS4586.</li> <li>R11 when tested in accordance with the oil-wet inclining platform test outlined in AS4586.</li> </ul>
<b>Relevant Standards and Codes</b>	<ul style="list-style-type: none"> <li>Austrroads GUIDE TO ROAD DESIGN PART 6A: PEDESTRIAN AND CYCLIST PATHS</li> <li>AS1428 Part 4.1 Design for access and mobility: Means to assist the orientation of people with vision impairment—Tactile ground surface indicators</li> <li>AS4586- Slip resistance classification of new pedestrian surface materials</li> </ul>
<b>Warranties</b>	Supply a warranty with Lake Macquarie City Council nominated as the warrantee for works in the public domain.

### 8.3 Concrete Pavement – Standard

Location	As noted in the Streetscape Master Plan
Colour	N/A
Finish	<ul style="list-style-type: none"> <li>Main body pavement and kerb ramps – Broom finish perpendicular to path of travel with a tooled edge.</li> <li>Driveway – Broom finish</li> </ul>
Standard Drawing Reference	<ul style="list-style-type: none"> <li>LSD-PAV-02 Concrete footpaths – full width, with banding and header (for town centres)</li> <li>LSD-PAV-04 Utility Lid in pavement</li> <li>EGSD-102 Kerb Ramps</li> <li>EGSD-104 Commercial and Industrial Vehicle Driveway &amp; Crossing.</li> <li>EGSD-301- Concrete Footpath</li> </ul>

### 8.4 Concrete Pavement – Coloured



Example of Bluestone colour

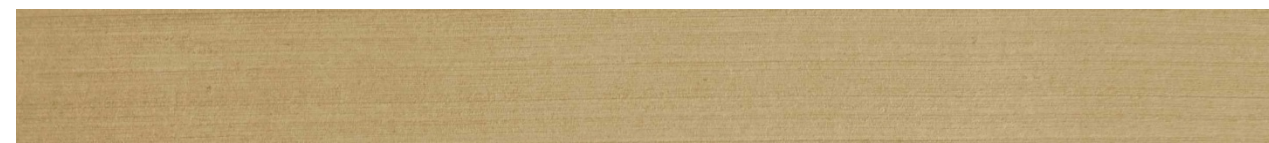

Example of Sahara colour

Location	As noted in the Streetscape Master Plan
Colour	<ul style="list-style-type: none"> <li>Main body pavement - grey cement base with CCS oxide “Bluestone” or approved equivalent.</li> <li>Driveway - grey cement base with CCS oxide “Bluestone” or approved equivalent.</li> <li>Kerb ramps- grey cement base with CCS oxide “Sahara” or approved equivalent.</li> </ul>
Finish	<ul style="list-style-type: none"> <li>Main body pavement and kerb ramps – Broom finish perpendicular to path of travel with a tooled edge.</li> <li>Driveways – Broom finish</li> </ul>
Standard Drawing Reference	<ul style="list-style-type: none"> <li>LSD-PAV-02 Concrete footpaths – full width, with banding and header (for town centres)</li> <li>LSD-PAV-04 Utility Lid in pavement</li> <li>EGSD-102 Kerb Ramps+</li> <li>EGSD-104 Commercial and Industrial Vehicle Driveway &amp; Crossing.</li> <li>EGSD-301- Concrete Footpath</li> </ul>

### Concrete Pavements and Kerb ramps- Guidance on design and specifying

Equal Access	<ul style="list-style-type: none"> <li>Ensure flush transitions between concrete pavements and other surfaces. Cross falls shall be 1:40, consistent with AS1428.1</li> <li>Vertical tolerances for paved surfaces on a continuous path of travel shall be +/-3mm in accordance with AS1428.1</li> </ul>
Environmental Sustainability	<ul style="list-style-type: none"> <li>Street pavements occupy a large part of a town centres area, providing significant opportunities to contribute to sustainability outcomes. The concrete pavement specifications within these Technical Guidelines and the Town Centre Palettes maximise durability to ensure a long service life with low maintenance requirements, therefore minimising the need to replace or re-instate pavements.</li> <li>Where appropriate, design pavement gradients to flow to mass planting, turf and tree pits.</li> <li>Concrete supplied is to use a Type GB blended cement with the highest amounts of fly ash/slag allowable under AS3972 to achieve the required concrete properties.</li> </ul>
Performance Criteria	
Traffic Loads	<ul style="list-style-type: none"> <li>Pavement design must be suitable for the expected traffic loads in relation to both strength and abrasion resistance.</li> <li>As a minimum, all town centre pedestrian pavements shall be designed to carry light traffic as vehicles may occasionally mount kerbs for maintenance, loading and unloading, special events etc.</li> <li>Design for heavier vehicle loads where heavy vehicles may traffic- adjacent driveways, residential flat buildings (for furniture deliveries etc.)</li> </ul>
Slip Resistance	
- For External walkways:	<ul style="list-style-type: none"> <li>P4 when tested in accordance with the wet pendulum test methods outlined in AS4586.</li> <li>R10 when tested in accordance with the oil-wet inclining platform test outlined in AS4586.</li> </ul>
- For External ramps:	<ul style="list-style-type: none"> <li>P5 when tested in accordance with the wet pendulum test methods outlined in AS4586.</li> <li>R11 when tested in accordance with the oil-wet inclining platform test outlined in AS4586.</li> </ul>
Special finishes	<ul style="list-style-type: none"> <li>Coloured pavements shall be coloured with mineral oxide UV resistant colourants, achieved through either: <ul style="list-style-type: none"> <li>An integral mix; or</li> <li>Monolithic topping (topping thickness to be min. 50mm)</li> </ul> </li> <li>Exposed aggregate pavements shall be achieved through either: <ul style="list-style-type: none"> <li>An integral mix with specified aggregates added into the mix by the concrete supplier ; or</li> <li>Monolithic topping (topping thickness to be 4 times the size of the coarse aggregate or 50mm, whichever is the greater.)</li> </ul> </li> <li>Special finishes require a minimum strength of 32MPa to meet abrasion resistance of finished surface.</li> <li>Finished path surfaces shall not deviate by more than 5mm on a 3m straight edge.</li> </ul>
Tolerances	<ul style="list-style-type: none"> <li>Finished path surfaces shall not deviate by more than 5mm on a 3m straight edge.</li> </ul>
Installation	<ul style="list-style-type: none"> <li>In accordance with Standard details below</li> </ul>
Quality Assurance	<ul style="list-style-type: none"> <li><b>Test Panels:</b> <ul style="list-style-type: none"> <li>Provide a single test panel for each type of special finish specified in the works. Non-critical areas of actual pavement to be used as test panels.</li> <li>Test panel(s) shall be reinforced to the same specifications as the cast in situ concrete, and shall incorporate all relevant features of the surface, ie, joint, grooves, openings and corners.</li> </ul> </li> <li>Inspections, Council’s nominated Project Officer is to carry out the following inspections: <ul style="list-style-type: none"> <li>Review of Test Panels- acceptance based on uniformity of aggregate exposure, uniformity of colour, alignment of joints and dowels.</li> <li>Sub-grade and sub-base prior to concrete slab being installed;</li> <li>Reinforcement in place ready for concrete pour;</li> <li>Finished concrete pavement;</li> </ul> </li> <li>Substitutions: <ul style="list-style-type: none"> <li>All proposed substitution of materials are to be approved in writing by Council’s Project Officer prior to the contractor placing orders.</li> </ul> </li> </ul>
Joints	<ul style="list-style-type: none"> <li>All joints to be continuous across the pavement.</li> <li>All joints to be sealed using high performances silicone or polyurethane joint sealant, applied when majority of dried shrinkage has occurred, and not applied during hot temperatures.</li> <li>Use clear or coloured sealants to match special concrete finishes.</li> </ul>
Protection of surfaces	<ul style="list-style-type: none"> <li>Ensure adequate protection of finished surfaces and test panels during remaining completion of works.</li> </ul>
Repair of Damage	<ul style="list-style-type: none"> <li>Where concrete pavements are damaged prior to completion of contract, the entire damaged panel will need to be replaced to eliminate patches and visual differences.</li> </ul>
Relevant Standards, Codes and Technical guidance	<ul style="list-style-type: none"> <li>Austroads GUIDE TO ROAD DESIGN PART 6A: PEDESTRIAN AND CYCLIST PATHS</li> <li>AS1428 Design for Access and Mobility Suite</li> <li>AS4586- Slip resistance classification of new pedestrian surface materials</li> <li>AS3972 General Purpose and Blended Cements</li> <li>CCAA Briefing 02- guide to exposed aggregate finishes</li> <li>CCAA Guide to Concrete flatwork finishes</li> </ul>



## 8.5 Cobble Setts

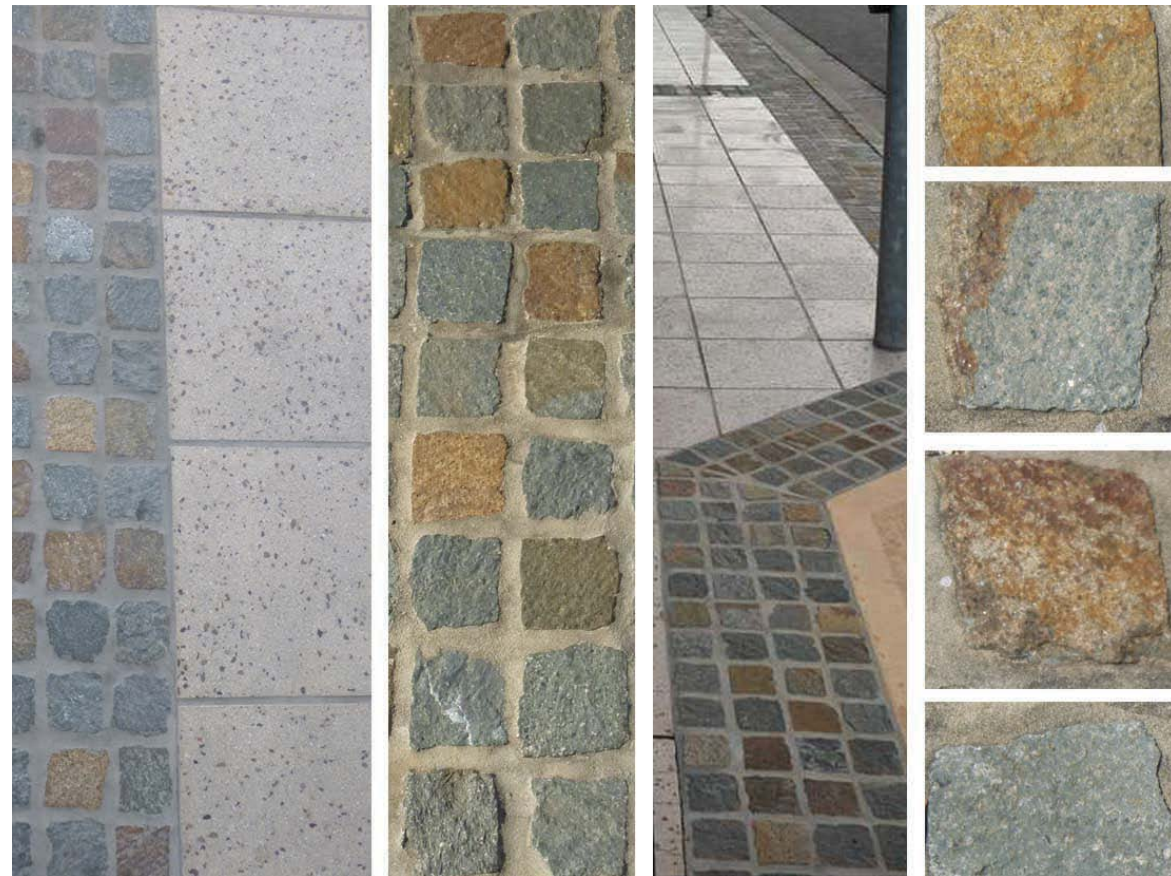

Example of existing Cobble Setts in Morisset Town Centre

<b>Colour</b>	Grey/orange (Similar to existing along Dora Street)  <b>Submit a sample of proposed cobble setts for approval by Council's nominated project officer prior to ordering project quantities. Note: Lead times will apply, check with suppliers.</b>
<b>Finish</b>	<ul style="list-style-type: none"> <li>• Top- Bush Hammer</li> <li>• Side – Chisel Cut</li> </ul>
<b>Dimensions</b>	Nom. 90x90mm
<b>Thickness</b>	Nominally 40-55mm (no thicker than adjacent pavers)
<b>Standard Drawing Reference</b>	<ul style="list-style-type: none"> <li>• LSD-PAV-01 Paver- large format for town centres</li> <li>• LSD-PAV-02 Concrete footpaths with pavers</li> </ul>

## Cobble Setts- Guidance on specifying and installing

<b>Positioning</b>	<ul style="list-style-type: none"> <li>• Generally continue cobble setts under surface mounted furniture items and cut cobble setts to finish up to the base of in-ground fixtures such as street signs, planter boxes and walls.</li> <li>• Provide a 10mm mastic expansion joint around in-ground fixtures.</li> </ul>
<b>Equal Access</b>	<ul style="list-style-type: none"> <li>• Vertical tolerances for paved surfaces on a continuous path of travel shall be +/-3mm in accordance with AS1428.1. Cross falls shall be 1:40, consistent with AS1428.1</li> <li>• Ensure flush transitions between adjoining cobble setts and other surfaces.</li> </ul>
<b>Environmental Sustainability</b>	<ul style="list-style-type: none"> <li>• Street pavements occupy a large part of a town centres area, providing significant opportunities to contribute to sustainability outcomes. The paver specifications within these Technical Guidelines maximise durability to ensure a long service life with low maintenance requirements, therefore minimising the need to replace or re-instate pavements.</li> <li>• Where appropriate, design pavement gradients to allow surface water to flow to mass planting, turf and tree pits.</li> </ul>
<b>Paver Performance Criteria Quality Assurance</b>	<ul style="list-style-type: none"> <li>• Cobble setts supplied shall be consistent with one another and samples.</li> <li>• Submit the following details to Council's nominated Project Officer: <ul style="list-style-type: none"> <li>- details of the proposed paver supplier and a samples of cobble setts proposed for use.</li> <li>- Confirmation from supplier that the proposed cobble setts comply with the performance criteria specified in these guidelines.</li> </ul> </li> </ul>
<b>Traffic Loads</b>	<ul style="list-style-type: none"> <li>• Pavement design must be suitable for the expected traffic loads in relation to both strength and abrasion resistance.</li> <li>• As a minimum, all town centre pedestrian pavements shall be designed to carry light traffic as vehicles may occasionally mount kerbs for maintenance, loading and unloading, special events etc.</li> <li>• Design for heavier vehicle loads where heavy vehicles may traffic- adjacent driveways, residential flat buildings (for furniture deliveries etc.), adjacent large pit lids that require mechanical lifting and shared zones.</li> </ul>
<b>Slip Resistance</b> - External walkways:	<ul style="list-style-type: none"> <li>• P4 when tested in accordance with the wet pendulum test methods outlined in AS4586.</li> <li>• R10 when tested in accordance with the oil-wet inclining platform test outlined in AS4586.</li> </ul>
<b>Slip Resistance</b> - External ramps:	<ul style="list-style-type: none"> <li>• P5 when tested in accordance with the wet pendulum test methods outlined in AS4586.</li> <li>• R11 when tested in accordance with the oil-wet inclining platform test outlined in AS4586.</li> </ul>
<b>Allowable Dimensional Deviations</b>	<ul style="list-style-type: none"> <li>• The cobble setts shall be sufficiently flat to enable the units to be laid in a pavement to give a functional and aesthetically acceptable surface.</li> </ul>
<b>Installation</b>	In accordance with the referenced Landscape Standard Drawings.
<b>Quality Assurance</b>	<ul style="list-style-type: none"> <li>• Submissions: The following must be submitted to Council's nominated Project Officer prior to execution of the paving works: <ul style="list-style-type: none"> <li>- Contractor's licences in accordance with Paving Contractor Requirements below;</li> <li>- Confirmation that a 'Plan of Survey Information' has been submitted to the NSW Dept. of Land and Property Information.</li> <li>- Samples of proposed cobble setts for approval by Council's nominated Project Officer prior to ordering project quantities.</li> </ul> </li> <li>• Inspections: Council's nominated Project Officer is to carry out the following inspections: <ul style="list-style-type: none"> <li>- Sub-grade and sub-base prior to concrete slab being installed;</li> <li>- Reinforcement in place ready for concrete pour;</li> <li>- Concrete slab ready for laying;</li> <li>- Commencement of segmental paving;</li> <li>- Completion of segmental paving.</li> </ul> </li> <li>• Paving Contractor Requirements: All paving work shall be undertaken/supervised by a Contractor with a current NSW Dept. of Fair Trading endorsed license in any of the following classes- Building, Structural Landscaping or Minor Trade-Paving.</li> </ul>
<b>Tolerances</b>	Maximum tolerance for deviations between adjoining cobble setts and with other surfaces shall be 2.5mm with a flatness deviation of 3mm using a 3m straight edge.
<b>Repairs</b>	Repair broken cobble setts immediately.
<b>Protection of surfaces</b>	Ensure adequate protection of finished surfaces during remaining completion of works.
<b>Relevant Standards and Codes</b>	<ul style="list-style-type: none"> <li>• <i>Austrroads GUIDE TO ROAD DESIGN PART 6B: ROADSIDE ENVIRONMENT</i></li> <li>• <i>Austrroads GUIDE TO ROAD DESIGN PART 6A: PEDESTRIAN AND CYCLIST PATHS</i></li> <li>• <i>AS1428 Design for Access and Mobility Suite</i></li> <li>• <i>AS4586 Slip resistance classification of new pedestrian surface materials</i></li> </ul>
<b>Warranties</b>	N/A



## 8.6 Permeable Pavers



<b>Type</b>	Fully interlocking concrete segmental permeable paver
<b>Shape</b>	Category A fully interlocking on all sides
<b>Thickness</b>	80mm
<b>Paver Colour</b>	Charcoal grey  <b>Submit a sample of proposed paving for approval by Council's nominated project officer prior to ordering project quantities.</b>
<b>Paver Finish</b>	Shot blast
<b>Standard Drawing Reference</b>	<ul style="list-style-type: none"> <li>• LSD-PLA-03 Tree Pit in road (flush, on-street parallel parking)</li> <li>• LSD-PLA-07 Tree Pit in Pavement</li> <li>• EGSD-410 Porous Paving</li> </ul>

## Pavers- Guidance on design and specifying

<b>Positioning</b> Set-out to furniture and in-ground fixtures	<ul style="list-style-type: none"> <li>• Generally continue pavers under surface mounted furniture items and cut pavers to finish up to the base of in-ground fixtures such as street signs, planter boxes and walls.</li> <li>• Provide a 10mm mastic expansion joint around in-ground fixtures.</li> </ul>																		
<b>Equal Access</b>	<ul style="list-style-type: none"> <li>• Cross falls shall be 1:40, consistent with AS1428.1</li> <li>• Ensure flush transitions between adjoining pavers and other surfaces.</li> </ul>																		
<b>Environmental Sustainability</b>	<ul style="list-style-type: none"> <li>• Street pavements occupy a large part of a town centres area, providing significant opportunities to contribute to sustainability outcomes. These paver specifications maximise durability to ensure a long service life with low maintenance requirements, therefore minimising the need to replace or re-instate pavements.</li> <li>• Where appropriate, design pavement gradients to allow surface water to flow to mass planting, turf and tree pits.</li> </ul>																		
<b>Paver Performance Criteria</b> Quality Assurance	<ul style="list-style-type: none"> <li>• Pavers supplied shall be consistent with one another and samples.</li> <li>• Submit the following details to Council's nominated Project Officer: <ul style="list-style-type: none"> <li>- details of the proposed paver supplier and a sample of each paver proposed for use.</li> <li>- Confirmation from supplier that the proposed pavers comply with the Performance Criteria specified in these guidelines, including slip resistance test results.</li> </ul> </li> </ul>																		
Traffic Loads	<p>Pavement design must be suitable for the expected traffic loads in relation to both strength and abrasion resistance. Definitions of Light vehicles and Commercial vehicles are in accordance with the <i>CMAA Concrete Flag Pavement Design and Construction Guide</i> as follows:</p> <ul style="list-style-type: none"> <li>• Light vehicles - vehicles that have a fully loaded weight less than 3 tonnes. As a minimum all town centre pavements and residential driveways are required to carry these loads.</li> <li>• Commercial vehicles - vehicles that have a gross weight of 3 tonnes or more. This category of pavement includes commercial driveways, footpaths subject to truck overrun or parking, pedestrian malls accepting service vehicles and lightly trafficked streets.</li> </ul>																		
Pavement application:	<table border="1"> <thead> <tr> <th></th> <th>Nom. Size (mm)</th> <th>Minimum thickness (mm)</th> <th>Characteristic breaking load (kN) when tested in accordance with AS 4456.5</th> </tr> </thead> <tbody> <tr> <td>Pedestrian and Light vehicles</td> <td>Any up to 450 x 450</td> <td>50</td> <td>7.0</td> </tr> <tr> <td rowspan="3">Pedestrian/Commercial vehicles</td> <td>300 x 300</td> <td>60</td> <td>13.8</td> </tr> <tr> <td>400 x 400</td> <td>65</td> <td>15.5</td> </tr> <tr> <td>450 x 450</td> <td>70</td> <td>18.8</td> </tr> </tbody> </table>		Nom. Size (mm)	Minimum thickness (mm)	Characteristic breaking load (kN) when tested in accordance with AS 4456.5	Pedestrian and Light vehicles	Any up to 450 x 450	50	7.0	Pedestrian/Commercial vehicles	300 x 300	60	13.8	400 x 400	65	15.5	450 x 450	70	18.8
	Nom. Size (mm)	Minimum thickness (mm)	Characteristic breaking load (kN) when tested in accordance with AS 4456.5																
Pedestrian and Light vehicles	Any up to 450 x 450	50	7.0																
Pedestrian/Commercial vehicles	300 x 300	60	13.8																
	400 x 400	65	15.5																
	450 x 450	70	18.8																
Slip Resistance - External walkways:	<ul style="list-style-type: none"> <li>• P4 when tested in accordance with the wet pendulum test methods outlined in AS4586.</li> <li>• R10 when tested in accordance with the oil-wet inclining platform test outlined in AS4586.</li> </ul>																		
- External ramps:	<ul style="list-style-type: none"> <li>• P5 when tested in accordance with the wet pendulum test methods outlined in AS4586.</li> <li>• R11 when tested in accordance with the oil-wet inclining platform test outlined in AS4586.</li> </ul>																		
Potential to effloresce	Nil to slight when tested in accordance with AS4456.6																		
Mean Abrasion resistance	3.5 when tested in accordance with AS4456.9																		
Allowable Dimensional Deviations	<ul style="list-style-type: none"> <li>• Mean allowable dimensional deviation is +/- 1.5mm (plan) and +/- 2mm (height).</li> <li>• The pavers shall be sufficiently flat to enable the units to be laid in a pavement to give a functional and aesthetically acceptable surface.</li> </ul>																		
<b>Installation</b> Quality Assurance	<p>In accordance with the referenced Landscape Standard Drawings.</p> <ul style="list-style-type: none"> <li>• Submissions: The following must be submitted to Council's nominated Project Officer prior to execution of the paving works: <ul style="list-style-type: none"> <li>- Contractor's licences in accordance with Paving Contractor Requirements below;</li> <li>- Confirmation that a 'Plan of Survey Information' has been submitted to the NSW Dept. of Land and Property Information.</li> <li>- Samples of proposed pavers for approval by Council's nominated Project Officer prior to ordering project quantities.</li> </ul> </li> <li>• Inspections: Council's nominated Project Officer is to carry out the following inspections: <ul style="list-style-type: none"> <li>- Sub-grade and sub-base prior to concrete slab being installed;</li> <li>- Reinforcement in place ready for concrete pour;</li> <li>- Concrete slab ready for laying;</li> <li>- Commencement of segmental paving;</li> <li>- Completion of segmental paving.</li> </ul> </li> <li>• Paving Contractor Requirements: All paving work shall be undertaken/supervised by a Contractor with a current NSW Dept. of Fair Trading endorsed license in any of the following classes- Building, Structural Landscaping or Minor Trade-Paving.</li> </ul>																		
Tolerances	Maximum tolerance for deviations between adjoining pavers and with other surfaces shall be 2.5mm with a flatness deviation of 3mm using a 3m straight edge.																		
Repairs	Repair broken pavers immediately.																		
Protection of surfaces	Ensure adequate protection of finished surfaces during remaining completion of works.																		
<b>Relevant Standards and Codes</b>	<ul style="list-style-type: none"> <li>• AS1428 Design for Access and Mobility Suite</li> <li>• AS4456 Masonry units and segmental pavers and flags Suite</li> <li>• AS4586 Slip resistance classification of new pedestrian surface materials</li> </ul>																		
<b>Warranties</b>	Supply a warranty with Lake Macquarie City Council nominated as the warrantee for works in the public domain.																		

## 9.0 Planting

9.1 Tree in Road	19
9.2 Tree in Footpath	19
9.3 Tree in Turf Verge	19
9.4 Turf	20
9.5 Mass Planting	20
9.6 Tree Guard	21
○ Standard	
○ Morisset feature infill panel	

## 9.1 Tree in Road

<b>Performance Criteria</b>	Refer to LSD – SPEC-01 Tree Planting Typical Specification
<b>Species</b>	Refer to the Street Tree Master Plan within the Morisset Streetscape Master Plan
<b>Permeable Pavers</b>	Refer to section - <b>Permeable Pavers</b> – under <b>Paving</b>
<b>Tree Guards</b>	Refer to section - <b>Tree Guards</b> – under <b>Planting</b>
<b>Standard Drawing Reference</b>	<ul style="list-style-type: none"> <li>LSD-PLA-03- Tree Pit in road (flush, on street parallel parking)</li> <li>LSD-SPEC-01- Tree Planting Typical Specification.</li> </ul>

## 9.2 Tree in Footpath

<b>Performance Criteria</b>	Refer to LSD – SPEC-01 Tree Planting Typical Specification
<b>Species</b>	Refer to the Street Tree Master Plan within the Morisset Streetscape Master Plan
<b>Permeable Pavers</b>	Refer to section - <b>Permeable Pavers</b> – under <b>Paving</b>
<b>Tree Guards</b>	Refer to section - <b>Tree Guards</b> – under <b>Planting</b>
<b>Standard Drawing Reference</b>	LSD-PLA-07 Tree Pit in Pavement LSD-SPEC-01- Tree Planting Typical Specification.

## 9.3 Tree in Turf Verge

<b>Performance Criteria</b>	Refer to LSD – SPEC-01 Tree Planting Typical Specification
<b>Species</b>	Refer to the Street Tree Master Plan within the Morisset Streetscape Master Plan
<b>Standard Drawing Reference</b>	LSD-PLA-01 Tree pit in Turf (with Footpath) LSD-SPEC-01- Tree Planting Typical Specification.

## New Trees – Guidance on design and specifying

<b>Positioning</b>	<ul style="list-style-type: none"> <li>Consider potential conflict with driveway locations, building awnings and utility services locations and co-ordinate the lighting, architectural and landscape designs to eliminate conflict.</li> <li>Council and other Government Authorities require clearances between street trees and other streetscape elements. Trees must be positioned to ensure mature canopy clearance: <ul style="list-style-type: none"> <li>Adequate clearances from Streetlights to achieve lighting design categories and subcategories.</li> <li>10m clearances from overhead power poles and lamp posts in accordance with Austroads Part 6B-Section 3.3.4- Landscaping Specific Situations</li> <li>6m clearances from drainage sumps in accordance with Austroads Part 6B-Section 3.3.4- Landscaping Specific Situations.</li> <li>2.5m clearance from centre of kerb inlet pits.</li> <li>Sightlines for vehicular traffic in accordance with LMCC standard details.</li> <li>3m clearances from edge of driveways</li> </ul> </li> <li>For proposals to install street trees within the parking lane of a roadway, consult with Council’s Infrastructure Strategy – Traffic Engineer to determine appropriate positioning and number of tree installations relevant to the site and extent of works.</li> </ul>
<b>Equal Access</b>	<ul style="list-style-type: none"> <li>There shall be 1800mm minimum accessible path of travel where the footpath adjoins building facades and property boundaries.</li> <li>The accessible path of travel must have a vertical clearance of 2000mm in accordance with AS1428.1. and AS1428.2</li> <li>Mature tree canopies shall not encroach into this accessible path of travel.</li> </ul>
<b>Environmental Sustainability</b>	The provision of street trees is an objective for development in both Business and Residential zones under the LMDCP2014 . Suitably selected species with a sound structure provide many environmental benefits including urban amenity, microclimate, scenic quality, air and water quality, wildlife habitat, wind protection and social and psychological values.
<b>Tree Quality Installation</b>	Specified trees must comply with AS2303- Part 2,Part 3 and Part 4.
<b>Quality Assurance</b>	<ul style="list-style-type: none"> <li>Submissions: The following must be submitted to Council’s nominated Project Officer prior to execution of the planting works: <ul style="list-style-type: none"> <li>Contractor’s licences in accordance with Planting Contractor Requirements below;</li> <li>Dispatch Tree Stock Inspection Checklists in accordance with AS2303-2015 Appendix C- Example A confirming trees meet performance criteria listed above.</li> <li>Certification that soils (including filter material and structural soils) comply with the approved project documentation.</li> </ul> </li> <li>Planting Contractor Requirements- All tree planting work shall be undertaken/supervised by a Contractor with a current NSW Dept. of Fair Trading endorsed license in the following class- Structural Landscaping.</li> <li>Inspections: Inspections must be carried out by Council’s nominated Project Officer at the following points: <ul style="list-style-type: none"> <li>Set out of tree pits complete, prior to excavation;</li> <li>Tree pits excavated;</li> <li>Root barrier installed;</li> <li>Structural soils /permeable paving base courses installed;</li> <li>Trees delivered to site and ready for planting;</li> <li>Completion of planting.</li> </ul> </li> </ul>
<b>Relevant Standards and Codes</b>	<ul style="list-style-type: none"> <li>LMCC Landscape Design Guidelines</li> <li>AS2303- Tree Stock for Landscape Use</li> <li>Austroads GUIDE TO ROAD DESIGN PART 6A – Pedestrian and Cyclist Paths</li> <li>Austroads GUIDE TO ROAD DESIGN PART 6B – Roadside Environment</li> <li>AS1428 Design for access and mobility Suite</li> </ul>
<b>Maintenance and Establishment</b>	<ul style="list-style-type: none"> <li>Refer to LMCC DCP 2014 for Maintenance and Establishment periods for different zonings. If not designated in the DCP, the maintenance and establishment period shall be 52 weeks from installation of trees unless otherwise noted in conditions of consent.</li> <li>Refer to the LMCC Landscape Design Guidelines for checklist requirements during the plant establishment and contract maintenance periods.</li> <li>Refer to LSD-SPEC-01 Tree Planting Specification for details of maintenance and establishment tasks.</li> </ul>

## 9.4 Turf

### Guidance on design and specifying

<b>Location</b>	<ul style="list-style-type: none"> <li>• Locate as identified in the Streetscape Master Plan</li> <li>• Locate to make good existing turf areas damaged through the course of the works.</li> </ul>
<b>Positioning</b>	<ul style="list-style-type: none"> <li>• Lay turf along contours with close-butted joints.</li> <li>• Finish turf flush with adjacent surfaces .</li> </ul>
<b>Equal Access</b>	Turf shall be installed +/- 10mm from flush with adjacent clear paths of travel to provide a stable, level edge of path.
<b>Environmental Sustainability</b>	<ul style="list-style-type: none"> <li>• Turf provides a permeable surface within urban areas, reducing stormwater run-off.</li> <li>• Turf provides a valuable function when used as a filter or buffer strip to remove first flush pollutants from urban Stormwater Quality Improvement Devices (SQIDs).</li> </ul>
<b>Performance Criteria</b>	Turf shall be free from weeds and grass species other than specified.
<b>Installation</b>	Refer to LSD-PLA-22 – Turf Planting (Typical)
<b>Quality Assurance</b>	<p>Submissions: The following must be submitted to Council’s nominated Project Officer prior to execution of turfing:</p> <ul style="list-style-type: none"> <li>○ Certification that soils and additives comply with the standards referenced in this specification and approved project documentation.</li> <li>○ Certification from turf supplier that turf material is compliant with this specification and the approved project documentation.</li> </ul>
<b>Relevant Standards and Codes</b>	<ul style="list-style-type: none"> <li>• LMCC Landscape Design Guidelines</li> <li>• LMCC Engineering Construction Guidelines- 0257- Landscape roadways and street trees</li> <li>• AS4419- Soils for Landscape and Garden Use</li> <li>• AS4454-Composts, soil conditioners and mulches</li> </ul>
<b>Standard Drawing Reference</b>	<ul style="list-style-type: none"> <li>• LSD-PLA-22 – Turf Planting (Typical)</li> <li>• LSD-SPEC-01- Tree Planting Specification</li> </ul>
<b>Maintenance and Establishment</b>	Refer to the LMCC Landscape Design Guidelines for checklist requirements during the plant establishment and contract maintenance periods.

## 9.5 Mass Planting

### Guidance on design and specifying

<b>Location</b>	<ul style="list-style-type: none"> <li>• Locate as identified in the Streetscape Master Plan</li> <li>• Locate to make good existing mass planted areas damaged through the course of the works.</li> </ul>
<b>Positioning</b>	<ul style="list-style-type: none"> <li>• Setback plants 500mm – 1000mm (setback appropriate to mature spread of selected species) from edge of pavements to ensure mass planting does not overhang pavements.</li> <li>• Consider conflicts with people alighting from parked cars and access other street furniture elements when positioning mass planting.</li> </ul>
<b>Equal Access</b>	<ul style="list-style-type: none"> <li>• There shall be 1800mm minimum accessible path of travel where the footpath adjoins building facades and property boundaries.</li> <li>• The accessible path of travel must have a vertical clearance of 2000mm in accordance with AS1428.1. and AS1428.2</li> <li>• Mass planting shall not encroach into this accessible path of travel.</li> <li>• Finished mulch levels shall finish flush (+/-10mm)from adjacent clear paths of travel to provide a stable, level edge of path.</li> </ul>
<b>Environmental Sustainability</b>	<ul style="list-style-type: none"> <li>• Mass planting in urban areas provides opportunities for stormwater capture and water quality improvement. Mass planting also provides opportunities to reinforce sense of place and highlight endemic species of the locality.</li> <li>• Selections for mass planting species in town centres should be suitable for the tough microclimatic conditions present in urban areas, and where appropriate preference to local indigenous species and plant material of local provenance- refer to the LMCC Landscape design guidelines for further details.</li> </ul>
<b>Performance Criteria</b>	<p>Plants shall be:</p> <ul style="list-style-type: none"> <li>• Of the species, size and quantities as shown on approved drawings;</li> <li>• Vigorous, well established, of good form true to type;</li> <li>• Free of pests and disease.</li> </ul>
<b>Installation</b>	
<b>Quality Assurance</b>	<p>Submissions: The following must be submitted to Council’s nominated Project Officer prior to execution of planting:</p> <ul style="list-style-type: none"> <li>• Certification that soils, additives and mulches comply with the standards referenced in this specification and the approved project documentation.</li> <li>• Certification from supplier that plant material is compliant with this specification and the approved project documentation.</li> </ul>
<b>Relevant Standards and Codes</b>	<ul style="list-style-type: none"> <li>• LMCC Landscape Design Guidelines</li> <li>• LMCC Engineering Construction Guidelines - 0257- Landscape roadways and street trees</li> <li>• AS4419- Soils for Landscape and Garden Use</li> <li>• AS4454-Composts, soil conditioners and mulches</li> </ul>
<b>Standard Drawing Reference</b>	<ul style="list-style-type: none"> <li>• LSD-PLA-21 – Mass Planting (Typical)</li> <li>• LSD-SPEC-01- Tree Planting Specification</li> </ul>
<b>Maintenance and Establishment</b>	Refer to the LMCC Landscape Design Guidelines for checklist requirements during the plant establishment and contract maintenance periods.



## 9.6 Tree Guard

### Standard

<b>Paint Colour</b>	<ul style="list-style-type: none"> <li>All timber to be finished in a colour equal to Taubmans "Cannon Ball" T10 55L-1. Undercoat and apply two coats as per manufacturer's specification.</li> </ul>
<b>Paint Finish</b>	<ul style="list-style-type: none"> <li>Low Sheen</li> </ul>
<b>Standard Drawing Reference</b>	Refer to LSD-GUA-01 Tree Guard (timber, typical)

### Morisset feature infill panel

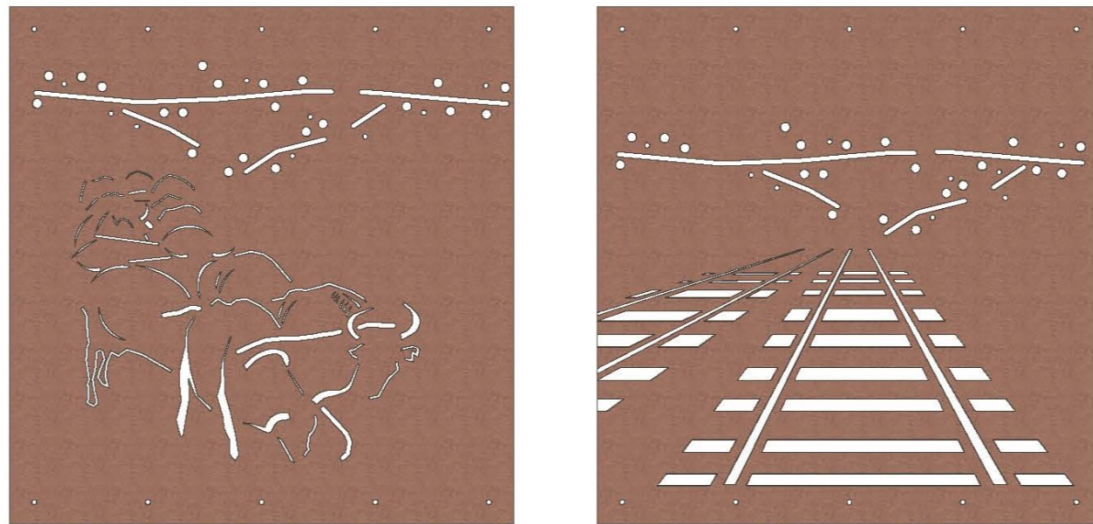

<b>Standard Drawing Reference</b>	<ul style="list-style-type: none"> <li>LSD-MO-CTG Morisset Tree Guard Custom Infill Panel</li> <li>LSD-GUA-01 Tree Guard (timber, typical)</li> </ul>
-----------------------------------	---

## Tree Guard – Guidance on design and specifying

<b>Positioning</b>	<ul style="list-style-type: none"> <li>Provide setbacks from face of kerb in accordance with the referenced standard details to minimise conflict with opening car doors.</li> <li>Consider impacts tree guards will have on pedestrian and vehicle traffic sight lines, and adjust tree locations accordingly.</li> </ul>
<b>Equal Access</b>	<ul style="list-style-type: none"> <li>There shall be 1800mm minimum accessible path of travel where the footpath adjoins building facades and property boundaries.</li> <li>The accessible path of travel must have a vertical clearance of 2000mm in accordance with AS1428.1. and AS1428.2</li> <li>Tree guards shall not encroach into this accessible path of travel.</li> </ul>
<b>Environmental Sustainability</b>	<ul style="list-style-type: none"> <li>Tree guard design maximises durability and life span, specifying robust vandal and corrosion resistant materials.</li> <li>Tree guard design provides fixings and materials junctions that provide removal and re-use options for infill panels and decorative elements.</li> </ul>
<b>Relevant Standards and Codes</b>	<ul style="list-style-type: none"> <li>AS1428 Design for Access and Mobility Suite</li> <li>AS1604.1 Specification for preservative treatment - sawn and round timber</li> </ul>

### 10.0 Light poles

<b>10.1 Street lighting</b>	<b>23</b>
<b>10.2 Pedestrian lighting</b>	<b>23</b>

Note: there are no selections for lighting in Morisset. Any proposed installations must be submitted to Council for approval.

## 10.1 Street Lighting

### Guidance on design and specifying

<b>Location</b>	<ul style="list-style-type: none"> <li>Locate Street lighting in accordance with Council's Public Lighting Policy.</li> <li>Additional lighting may be necessary at certain locations such as pedestrian facilities.</li> </ul>
<b>Positioning</b>	<ul style="list-style-type: none"> <li>In accordance with Ausgrid Network Standard NS167 Positioning of Poles and Lighting Columns</li> <li>In accordance with Ausgrid Network Standard NS128 Specification for Pole Installation and removal.</li> <li>In accordance with LMCC Standard Drawing EGSD-303 Footway allocation utility services and trees</li> <li>Consider potential conflict with building awnings and street tree locations and co-ordinate the lighting, architectural and landscape designs to eliminate conflict.</li> </ul>
<b>Equal Access</b>	<ul style="list-style-type: none"> <li>There shall be 1800mm minimum accessible path of travel where the footpath adjoins building facades and property boundaries.</li> <li>The accessible path of travel must have a vertical clearance of 2000mm in accordance with AS1428.1. and AS1428.2</li> <li>Street lighting shall not encroach into accessible paths of travel.</li> </ul>
<b>Digital Connectivity</b>	<ul style="list-style-type: none"> <li>Consider where digital technology is appropriate to the function of a space. Generally this will be located in public domain plazas, nodes and key places where benefit will be derived from smart technology.</li> <li>Locate and provide in accordance with Lake Macquarie: The Smart City Guidelines for Integrating Emerging Technology into the Built Environment.</li> </ul>
<b>Environmental Sustainability</b>	<ul style="list-style-type: none"> <li>Council aims to reduce energy consumption and eliminate unnecessary energy use by installing lights to locations outlined in the LMCC Public Lighting Policy, to the level required to meet the applicable lighting category.</li> <li>Poles and luminaires should be made from robust materials, and designed to minimise corrosion and vandalism opportunities.</li> </ul>
<b>Performance Criteria</b>	<ul style="list-style-type: none"> <li>Must meet the requirements of the AS1158 Suite to provide the required lighting category and sub category. Consult with Council's Infrastructure Strategy Technical Officer to determine the appropriate Sub- category.</li> <li>Minimise energy consumption by utilising energy efficient light fixtures such as LED's.</li> <li>Energy absorbing or rigid poles are preferred. <b>Slip base frangible poles are not recommended for pedestrian areas.</b></li> <li>Consider multi-function poles with a modular design to allow future digital augmentation and connectivity.</li> <li>Shall be fabricated from robust materials fit for purpose.</li> <li>Finishes on all materials to maximise corrosion resistance suitable to the intended light location.</li> </ul>
<b>Fabrication and Installation</b>	<ul style="list-style-type: none"> <li>Must meet the requirements of the relevant Australian standards.</li> <li>Must meet energy provider requirements and road authority requirements.</li> <li>Affix a label identifying the pole owner in accordance with the NSW Service and Installation Rules 3.7.2.2 Labelling of Private Posts/Poles</li> </ul>
<b>Relevant Standards and Codes</b>	<ul style="list-style-type: none"> <li>AS1158 Suite - Lighting for Roads and Public Spaces</li> <li>AS1798 Lighting Poles and Bracket arms- recommended dimensions</li> <li>AS/NZS 3000- Electrical Installations</li> <li>LMCC Public Lighting Policy</li> <li>LMCC Public Lighting Guidelines</li> <li>Lake Macquarie: The Smart City Guidelines for Integrating Emerging Technology into the Built Environment.</li> <li>RMS Model Drawings Street lighting(R72)</li> <li>Ausgrid Network Standard NS119 STREET LIGHTING DESIGN AND CONSTRUCTION</li> <li>Ausgrid Network Standard NS167 POSITIONING OF POLES AND LIGHTING COLUMNS</li> <li>Ausgrid Network Standard NS 128 SPECIFICATION FOR POLE INSTALLATION AND REMOVAL.</li> <li>Austrroads GUIDE TO ROAD DESIGN PART 6B: ROADSIDE ENVIRONMENT</li> <li>Austrroads GUIDE TO ROAD DESIGN PART 6A: PEDESTRIAN AND CYCLIST PATHS</li> <li>NSW Service and Installation Rules- Trade and Investment Resources and Energy</li> </ul>

## 10.2 Pedestrian Lighting

### Guidance on design and specifying

<b>Location</b>	Locate Pedestrian lighting in accordance with Council's Public Lighting Policy.
<b>Positioning</b>	<p>Consider potential conflict with building awnings and street tree locations and co-ordinate the lighting, architectural and landscape designs to eliminate conflict.</p> <p>For pole mounted lights:</p> <ul style="list-style-type: none"> <li>In accordance with Ausgrid Network Standard NS167 Positioning of Poles and Lighting Columns</li> <li>In accordance with Ausgrid Network Standard NS128 Specification for Pole Installation and removal.</li> </ul> <p>For awning mounted:</p> <ul style="list-style-type: none"> <li>Position as required to achieve required lighting category.</li> <li>Position to ensure required clearances from utility services, clear paths of travel and signage.</li> </ul>
<b>Equal Access</b>	<ul style="list-style-type: none"> <li>There shall be 1800mm minimum accessible path of travel where the footpath adjoins building facades and property boundaries.</li> <li>The accessible path of travel must have a vertical clearance of 2000mm in accordance with AS1428.1. and AS1428.2</li> <li>Pedestrian lighting shall not encroach into accessible paths of travel.</li> </ul>
<b>Digital Connectivity</b>	<ul style="list-style-type: none"> <li>Consider where digital technology is appropriate to the function of a space. Generally this will be located in public domain plazas, nodes and key places where benefit will be derived from smart technology.</li> <li>Locate and provide in accordance with Lake Macquarie: The Smart City Guidelines for Integrating Emerging Technology into the Built Environment.</li> </ul>
<b>Environmental Sustainability</b>	<ul style="list-style-type: none"> <li>Council aims to reduce energy consumption and eliminate unnecessary energy use by installing lights to locations outlined in the LMCC Public Lighting Policy, to the level required to meet the applicable lighting category.</li> <li>Pedestrian lighting fittings, brackets and poles should be made from robust materials, and designed to minimise corrosion and vandalism opportunities.</li> </ul>
<b>Performance Criteria</b>	<ul style="list-style-type: none"> <li>Must meet the requirements of the AS1158 Suite to provide the required lighting category and sub category. Consult with Council's Infrastructure Strategy Technical Officer to determine the appropriate Sub- category.</li> <li>Minimise energy consumption by utilising energy efficient light fixtures such as LED fittings.</li> <li>Energy absorbing or rigid poles are preferred. <b>Slip base frangible poles are not recommended for pedestrian areas.</b></li> <li>Consider multi-function poles with a modular design to allow future digital augmentation and connectivity.</li> <li>Shall be fabricated from robust materials fit for purpose.</li> <li>Finishes on all materials to maximise corrosion resistance suitable to the intended light location.</li> </ul>
<b>Colour</b>	Refer to the town centre palette relevant to your development site.
<b>Height</b>	Refer to the town centre palette relevant to your development site.
<b>Luminaire type</b>	Refer to the town centre palette relevant to your development site.
<b>Fabrication and Installation</b>	<ul style="list-style-type: none"> <li>Must meet the requirements of the relevant Australian standards.</li> <li>For lighting poles - affix a label identifying the pole owner in accordance with the NSW Service and Installation Rules 3.7.2.2 Labelling of Private Posts/Poles</li> <li>Must meet energy provider requirements and road authority requirements.</li> </ul>
<b>Relevant Standards and Codes</b>	<ul style="list-style-type: none"> <li>AS1158 Suite - Lighting for Roads and Public Spaces</li> <li>AS/NZS 3000- Electrical Installations</li> <li>LMCC Public Lighting Policy</li> <li>LMCC Public Lighting Guidelines</li> <li>Lake Macquarie: The Smart City Guidelines for Integrating Emerging Technology into the Built Environment.</li> <li>Ausgrid Network Standard NS119 STREET LIGHTING DESIGN AND CONSTRUCTION</li> <li>Ausgrid Network Standard NS167 POSITIONING OF POLES AND LIGHTING COLUMNS</li> <li>Ausgrid Network Standard NS 128 SPECIFICATION FOR POLE INSTALLATION AND REMOVAL.</li> <li>Austrroads GUIDE TO ROAD DESIGN PART 6B: ROADSIDE ENVIRONMENT</li> <li>Austrroads GUIDE TO ROAD DESIGN PART 6A: PEDESTRIAN AND CYCLIST PATHS</li> <li>NSW Service and Installation Rules- Trade and Investment Resources and Energy</li> </ul>

## 11.0 Furniture

<b>11.1 Bike Rack – Single Loop</b>	<b>25</b>
<b>11.2 Bollard - Standard</b>	<b>26</b>
<b>11.3 Drinking Fountain</b>	<b>27</b>
<b>11.4 Waste Receptacles</b>	<b>28</b>
<b>11.5 Seat - Standard</b>	<b>29</b>
<b>11.6 Seat - Morisset Custom</b>	<b>29</b>



### 11.1 Bike Racks

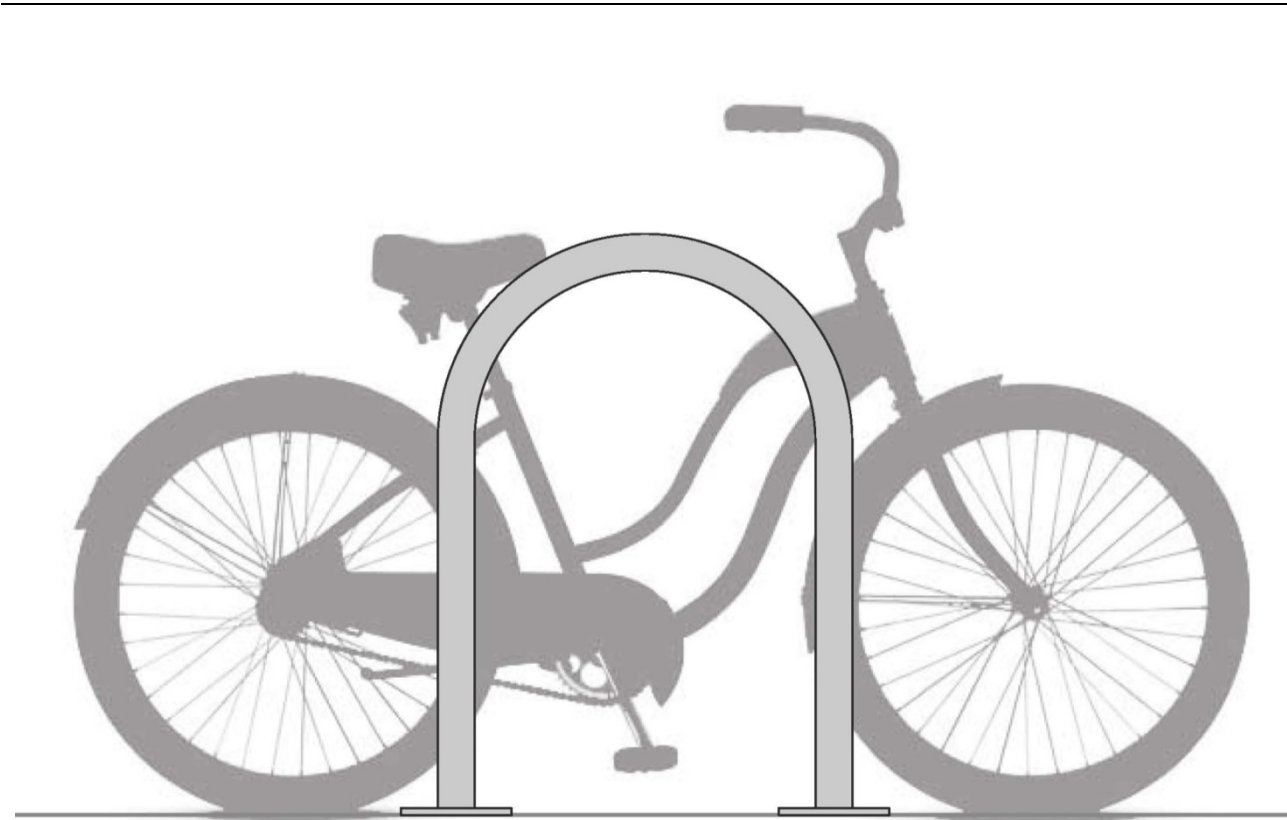

<b>Performance Criteria</b>	<ul style="list-style-type: none"> <li>• Shall be structurally capable of supporting a bicycle and resistant to cutting, bending or breaking.</li> <li>• Surface mount to pavement. Fixings used shall be secure and not easily removed with ordinary tools.</li> <li>• Shall provide safe and secure access with regard to both the user and the bicycle itself.</li> </ul>
<b>Material</b>	Constructed from Grade 304 Stainless Steel pipe
<b>Finish</b>	Electro-polished, max surface roughness <5microns.
<b>Shape</b>	Single loop – inverted ‘U’ shape
<b>Dimension</b>	<ul style="list-style-type: none"> <li>• Nom. 950 x 800mm</li> </ul> Bike rack dimensions shall allow locking the frame and <b>both</b> wheels of a bicycle to the bike racks by chain, cable or U-lock without removal of a wheel from the bicycle.
<b>Standard Drawing Reference</b>	LSD-BKR-01 – Bike Racks (Typical)

### Bike Racks – Guidance on design and specifying

<b>Location</b>	<ul style="list-style-type: none"> <li>• Locate as identified in the Streetscape Master Plans.</li> <li>• All bicycle parking should be accessible from a road, or bicycle-friendly access path, away from the desired walking line of pedestrians and as close as possible to the cyclist’s destination.</li> <li>• Provide bike racks at destinations such as:               <ul style="list-style-type: none"> <li>○ near main entries to buildings and retail spaces;</li> <li>○ in proximity dining and entertainment venues;</li> <li>○ at gathering places and open spaces.</li> </ul> </li> </ul>
<b>Positioning</b>	<ul style="list-style-type: none"> <li>• Allow sufficient clearance - min. 2250 from centreline of racks to wall/property boundary– to maintain clear paths of travel for circulation around the rack installation, including for maintenance cleaning.</li> <li>• Racks may be oriented parallel to the kerb or at an angle of 45-90 degrees from the kerb alignment depending on the available footpath width and accessible path of travel requirements.</li> <li>• Set-out and spacing of racks must be in accordance with Australian Standards for bicycle parking. AS 2890.3, including offsets from back of kerb to avoid damage to parked bicycles from opening car doors.</li> <li>• Consider potential conflict with driveway locations, utility services locations and co-ordinate the lighting, engineering, architectural and landscape designs to eliminate conflict.</li> </ul>
<b>Equal Access</b>	<ul style="list-style-type: none"> <li>• There shall be 1800mm minimum accessible path of travel where the footpath adjoins building facades and property boundaries. Bike racks with parked bicycles shall not encroach into this accessible path.</li> <li>• Bike racks installed adjacent to public access ways should provide a minimum 30% colour contrast to the background pavement, wall, fence or vertical surface to enhance detection by people with low vision.</li> <li>• Bike racks located in public domain plazas should not be placed where pedestrians could be expected to walk, on desire lines or in areas of heavy pedestrian traffic. If the racks are not set back from primary pedestrian access ways then hazard warning tactile ground surface indicators should be installed, in accordance with AS 1428.4.1.</li> </ul>
<b>Digital Connectivity</b>	<ul style="list-style-type: none"> <li>• Consider where digital technology is appropriate to the function of a space. Generally this will be located in public domain plazas, nodes and key places where benefit will be derived from smart technology.</li> <li>• Locate and provide in accordance with Lake Macquarie: The Smart City Guidelines for Integrating Emerging Technology into the Built Environment.</li> </ul>
<b>Environmental Sustainability</b>	<ul style="list-style-type: none"> <li>• Provision of secure, convenient bicycle parking facilities support the up-take of active transport within the City, which is a target in the City Of Lake Macquarie Environmental Sustainability Action Plan 2014-23.</li> <li>• Installation of products to enable re-location and re-use.</li> </ul>
<b>Installation</b>	<ul style="list-style-type: none"> <li>• Surface -mount to minimise damage to pavements if replacement or relocation is required.</li> <li>• Use nylon grommets/sleeves at junctions between stainless steel and other metallic materials to prevent galvanic corrosion.</li> <li>• Consult product supplier to determine suitable fixing and footing requirements.</li> <li>• Fixing and footings for custom elements require sign off by the project’s Engineer.</li> </ul>
<b>Relevant Standards and Codes</b>	<ul style="list-style-type: none"> <li>• AS2890.3- Bicycle Parking</li> <li>• AS1428 Design for Access and mobility Suite</li> <li>• Lake Macquarie: The Smart City Guidelines for Integrating Emerging Technology into the Built Environment.</li> </ul>

## 11.2 Bollard - Standard

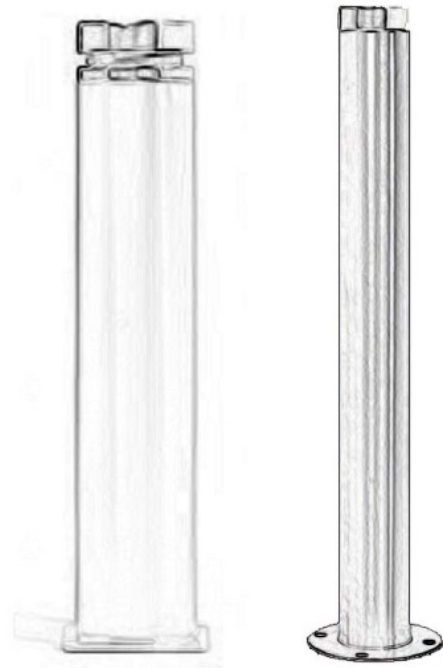

Examples of bollard with collar designs

<b>Materials &amp; Finish</b>	<ul style="list-style-type: none"> <li>316 Stainless steel</li> <li>Flat top with collar</li> </ul>
<b>Dimension</b>	165 Ø pipe, 1000 height
<b>Installation</b>	<ul style="list-style-type: none"> <li>Surface -mount to minimise damage to pavements if replacement or relocation is required.</li> <li>Consult product supplier to determine suitable fixing and footing requirements.</li> </ul>
<b>Standard Drawing Reference</b>	N/A

### Bollards – Guidance on design and specifying

<b>Location</b>	<ul style="list-style-type: none"> <li>Locate to prevent and deter vehicle access to prevent damage to pavements, for example, at building entries – particularly residential buildings where furniture trucks may pull up and where pavements are not designed for heavier loadings.</li> <li>May be used to protect vegetation from vehicles, especially associated with shared zone or car park areas.</li> <li><b>Note:</b> surface mounted bollards are not intended to protect crowded places from hostile vehicle attack. Refer to ‘Hostile Vehicle Guidelines for Crowded Places’ published by the Commonwealth Attorney-General’s Department for guidance on design considerations to minimise damage from hostile vehicle attack.</li> </ul>
<b>Positioning</b>	<ul style="list-style-type: none"> <li>Offset bollards 800mm from the front face of kerbs and edges of vehicle parking lanes to avoid risk of damage from opening car doors.</li> <li>Provide sufficient clearance to maintain accessible paths of travel and circulation around the bollard installation, including for maintenance cleaning.</li> <li>Where used to prevent vehicle access, space at maximum 1500mm centres.</li> </ul>
<b>Equal Access</b>	<ul style="list-style-type: none"> <li>There shall be 1800mm minimum accessible path of travel where the footpath adjoins building facades and property boundaries. Bollards shall not encroach into this accessible path.</li> <li>Bollards installed adjacent to public access ways should provide a minimum 30% colour contrast to the background pavement, wall, fence or vertical surface to enhance detection by people with low vision;</li> <li>Bollards located in public domain plazas should not be placed where pedestrians could be expected to walk, on desire lines or in areas of heavy pedestrian traffic. If the bollards are not set back from primary pedestrian access ways then hazard warning tactile ground surface indicators should be installed, in accordance with AS 1428.4.1.</li> </ul>
<b>Digital Connectivity</b>	<ul style="list-style-type: none"> <li>Consider where digital technology is appropriate to the function of a space. Generally this will be located in public domain plazas, nodes and key places where benefit will be derived from smart technology.</li> <li>Locate and provide in accordance with LMCC Guidelines for Emerging Technology</li> </ul>
<b>Environmental Sustainability</b>	<ul style="list-style-type: none"> <li>Bollard serviceable life span should be maximised through: <ul style="list-style-type: none"> <li>design to minimise corrosion and vandalism opportunities;</li> <li>construction from robust materials;</li> <li>Installation in accordance with approved project documentation.</li> <li>Installation to enable re-location and re-use.</li> </ul> </li> </ul>
<b>Performance Criteria</b>	<ul style="list-style-type: none"> <li>Shall be constructed from robust materials fit for purpose.</li> <li>Shall be constructed from materials, and/or have finishes and coatings, that provide ease of cleaning and graffiti removal.</li> <li>Finishes on all materials to maximise corrosion resistance suitable to the intended bollard location.</li> <li>Removable, fold-down or mechanically actuated retractable bollards may be required depending on the situation and/or lease arrangements.</li> <li>Minimum 1000mm high x 100-300mm internal diameter.</li> <li>Fixings used shall be secure and not easily removed with ordinary tools. Use nylon grommets/sleeves at junctions between stainless steel and other metallic materials to prevent galvanic corrosion.</li> <li>Provide a securely fitted cap fabricated from the same material as the bollard.</li> </ul>
<b>Relevant Standards and Codes</b>	<ul style="list-style-type: none"> <li>Austrroads GUIDE TO ROAD DESIGN PART 6B: ROADSIDE ENVIRONMENT</li> <li>Austrroads GUIDE TO ROAD DESIGN PART 6A: PEDESTRIAN AND CYCLIST PATHS</li> <li>AS1428 Design for Access and Mobility Suite</li> <li>NSW Bicycle Guidelines (RTA,2005)</li> <li>‘Hostile Vehicle Guidelines for Crowded Places’ published by the Commonwealth Attorney-General’s Department</li> <li>Lake Macquarie: The Smart City Guidelines for Integrating Technology into the Built Environment.</li> </ul>

### 11.3 Drinking Fountains

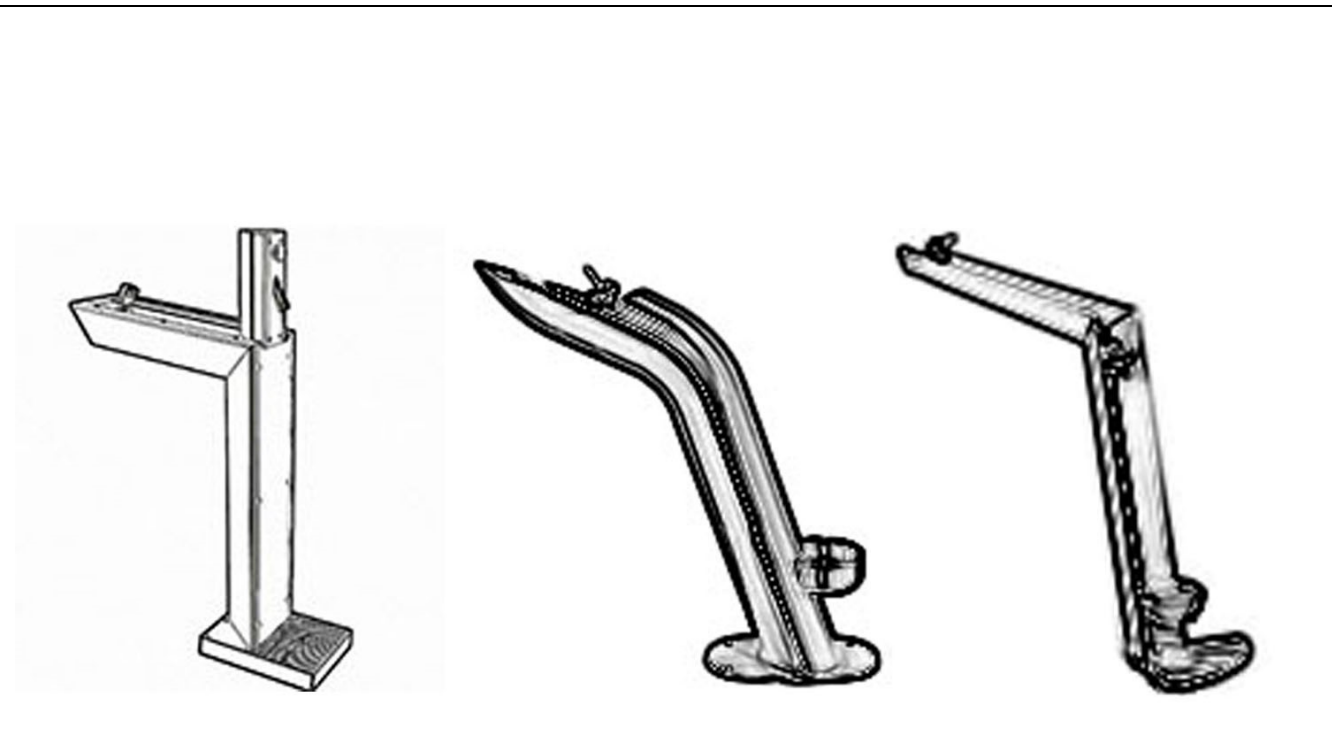

Examples of cantilever drinking fountain designs

<b>Product</b>	Cantilever style wheelchair accessible drinking fountain. Desirable features: - Dog bowl - Bottle refill tap
<b>Material</b>	Stainless Steel
<b>Finish</b>	Electro Polish or mirror finish
<b>Standard Drawing Reference</b>	N/A

### Drinking Fountains - Guidance on design and specifying

<b>Location</b>	<ul style="list-style-type: none"> <li>Locate as identified in the Streetscape Master Plans.</li> <li>Consider whether a drinking fountain is appropriate to the function of a space. Generally will be located to open spaces and public domain plaza's where groups of people may gather, and where urban activities such as performance, parour and skating may occur.</li> </ul>
<b>Positioning</b>	<ul style="list-style-type: none"> <li>Provide adequate circulation space around the fixture for wheelchair access and pedestrian movement.</li> <li>If located adjacent vehicle parking areas, position drinking fountains with sufficient clearances from the face of kerb (min 800mm) to avoid risk of damage from car doors.</li> <li>Consider potential conflict with driveway locations, building awnings and utility services locations and co-ordinate the lighting, engineering, architectural and landscape designs to eliminate conflict.</li> <li>Allow sufficient clearance to maintain clear paths of travel for circulation around the fountain installation, including for maintenance cleaning.</li> </ul>
<b>Equal Access</b>	<ul style="list-style-type: none"> <li>Fountain dimensions and requirements shall meet the criteria outlined in AS1428.2 – Section 27.3</li> <li>Provide hard paving and smooth transitions for wheelchair access.</li> <li>There shall be 1800mm minimum accessible path of travel where the footpath adjoins building facades and property boundaries. Fountains shall not encroach into this accessible path.</li> <li>Fountains located in public domain plazas should not be placed where pedestrians could be expected to walk, on desire lines or in areas of heavy pedestrian traffic. If the fountains are not set back from primary pedestrian access ways then hazard warning tactile ground surface indicators should be installed, in accordance with AS 1428.4.1.</li> <li>Fountains installed adjacent to public access ways they should provide a minimum 30% colour contrast to the background pavement, wall, fence or vertical surface to enhance detection by people with low vision.</li> <li>Inclusion of dog-bowls are preferred to support assistance animals.</li> </ul>
<b>Digital Connectivity</b>	<ul style="list-style-type: none"> <li>Consider where digital technology is appropriate to the function of a space. Generally this will be located in public domain plazas, nodes and key places where benefit will be derived from smart technology.</li> <li>Locate and provide in accordance with Lake Macquarie: The Smart City Guidelines for Integrating Emerging Technology into the Built Environment.</li> </ul>
<b>Environmental Sustainability</b>	<ul style="list-style-type: none"> <li>Consider on-site water infiltration as an alternative to sewer drainage.</li> <li>Maximise serviceable life span through the performance criteria listed below.</li> <li>Inclusion of water bottle re-fill taps is preferred to reduce waste from single use plastic bottles.</li> </ul>
<b>Performance Criteria</b> Minimum requirements:	<ul style="list-style-type: none"> <li>Shall be constructed from robust materials fit for purpose.</li> <li>Materials and finishes selected to maximise corrosion resistance suitable to the intended fountain location.</li> <li>Materials and finishes selected to facilitate graffiti removal and minimise maintenance burdens - Stainless Steel must have an electro- polished or mirror finish to minimise tea staining.</li> <li>Attractive aesthetic design</li> <li>Accessible, refer to Equal Access requirements above.</li> </ul>
<b>Additional Options:</b>	<ul style="list-style-type: none"> <li>Tap option desirable (consider options for water collection under taps)</li> <li>Allowing Water Bottle refill</li> <li>Slim design provides less options for graffiti</li> <li>Options for signage to the rear of fountain. Can be linked to council, chambers, sustainability, way - finding.</li> <li>Drainage options – drainage pipe connection or on site water disposal.</li> <li>Dog bowl option desirable for flexibility at carefully selected &amp; council approved locations - likely to be less essential in paved areas.</li> </ul>
<b>Installation</b>	<ul style="list-style-type: none"> <li>Install on ground with a maximum gradient of 1 in 50. For sloping sites, design level pads to accommodate custom elements.</li> <li>Fixing and footings for custom elements require sign off by the project's Engineer.</li> <li>Install in accordance with the manufacturer's recommendations.</li> <li>Connect to potable water supply.</li> <li>Drain to sewer if infiltration not feasible.</li> </ul>
<b>Relevant Standards and Codes</b>	<ul style="list-style-type: none"> <li>Austroads GUIDE TO ROAD DESIGN PART 6A: PEDESTRIAN AND CYCLIST PATHS</li> <li>AS1428 Design for Access and Mobility Suite</li> <li>Lake Macquarie: The Smart City Guidelines for Integrating Emerging Technology into the Built Environment.</li> </ul>
<b>Warranties</b>	Provide warranty with LMCC as Warrantee.

### 11.4 Waste Receptacles

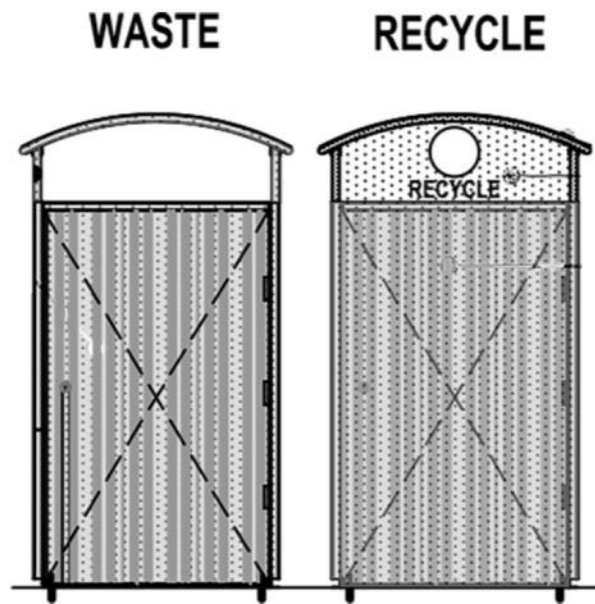

<b>Product</b>	Gossi Park Bayside bin sealed to slab or approved equivalent.
<b>Performance criteria</b>	<ul style="list-style-type: none"> <li>Anodised aluminium enclosure with sealed base/self-extinguishing design</li> <li>Slam door latch and triangular drive shaft lock system</li> <li>Fixed hood for waste enclosure</li> <li>Fixed hood with restrictor for recycling enclosures</li> </ul>
<b>Standard Drawing Reference</b>	LSD-BIN-01 Bin Enclosure

### Waste Receptacles - Guidance on design and specifying

<b>Location</b>	<ul style="list-style-type: none"> <li>Locate as identified in the Streetscape Master Plans.</li> <li>Select locations where there is potential to generate rubbish, eg. Bus stops, food outlets, open spaces and public plaza's.</li> <li>Consider the ease of servicing bin locations when determine bin locations within a street.</li> </ul>
<b>Positioning</b>	<ul style="list-style-type: none"> <li>If located adjacent vehicle parking areas, position receptacles with sufficient clearances (min 800mm) from the face of kerb to avoid risk of damage from car doors.</li> <li>Orient bins so that the access door does not open towards the roadway.</li> <li>Consider potential conflict with driveway locations, building awnings and utility services locations and co-ordinate the lighting, engineering, architectural and landscape designs to eliminate conflict.</li> <li>Allow sufficient clearance to maintain clear paths of travel for circulation around the receptacle installation, including for maintenance cleaning.</li> </ul>
<b>Equal Access</b>	<ul style="list-style-type: none"> <li>There shall be 1800mm minimum accessible path of travel where the footpath adjoins building facades and property boundaries. Waste receptacles shall not encroach into this accessible path.</li> <li>Waste Receptacles located in public domain plazas should not be placed where pedestrians could be expected to walk, on desire lines or in areas of heavy pedestrian traffic. If waste receptacles are not set back from primary pedestrian access ways then hazard warning tactile ground surface indicators should be installed, in accordance with AS 1428.4.1.</li> </ul>
<b>Digital Connectivity</b>	<ul style="list-style-type: none"> <li>Consider where digital technology is appropriate to the function of a space. Generally this will be located in public domain plazas, nodes and key places where benefit will be derived from smart technology.</li> <li>Locate and provide in accordance with Lake Macquarie: The Smart City Guidelines for Integrating Emerging Technology into the Built Environment.</li> </ul>
<b>Environmental Sustainability</b>	<ul style="list-style-type: none"> <li>Streetscape improvements provide the opportunity to deliver best practice waste management for public spaces.</li> <li>Planning and design should address practical collection sites and space suitable for separation of general waste, commingled recyclables and problem recyclables.</li> <li>Waste receptacles serviceable life span should be maximised through: <ul style="list-style-type: none"> <li>design to minimise corrosion and vandalism opportunities;</li> <li>construction from robust materials;</li> <li>Installation in accordance with approved project documentation.</li> </ul> </li> </ul>
<b>Installation</b>	<ul style="list-style-type: none"> <li>Install in accordance with the manufacturer's recommendations.</li> <li>Provide a 240 Litre mobile garbage bin at same time as enclosure installation.</li> <li>Refer to LSD-BIN-01 – Bin Enclosure</li> </ul>
<b>Relevant Standards and Codes</b>	<ul style="list-style-type: none"> <li>Austroads GUIDE TO ROAD DESIGN PART 6B: ROADSIDE ENVIRONMENT</li> <li>Austroads GUIDE TO ROAD DESIGN PART 6A: PEDESTRIAN AND CYCLIST PATHS</li> <li>AS1428 Design for Access and Mobility Suite</li> <li>Lake Macquarie: The Smart City Guidelines for Integrating Emerging Technology into the Built Environment.</li> </ul>
<b>Warranties</b>	Provide warranty with LMCC as Warrantee.



### 11.5 Seat – Standard

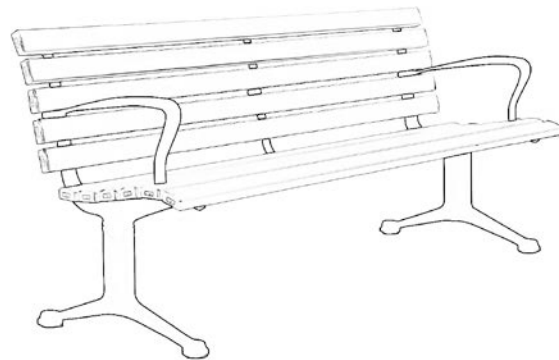

Example of a seat with Tee legs and armrests

<b>Type</b>	Seat with armrests to both ends
<b>Leg Shape</b>	Tee shape legs.
<b>Materials</b>	<ul style="list-style-type: none"> <li>Cast aluminium frame in marine grade (6061) aluminium.</li> <li>Extruded aluminium slats, clear anodised.</li> </ul>
<b>Dimension</b>	<ul style="list-style-type: none"> <li>Approx. 1800 long</li> </ul>
<b>Installation</b>	Surface mount in accordance with suppliers specifications.
<b>Standard Drawing Reference</b>	N/A – refer to manufacturer’s installation detail
<b>Warranties</b>	Provide warranty with LMCC as Warrantee.

### 11.6 Seat – Custom



Example of similar custom seat, located in Charlestown town centre.

<b>Materials</b>	Concrete base and backrests, timber slat seats.
<b>Shape and Dimensions</b>	Designer to develop details for seats based on the typical drawings shown in the Streetscape Master Plan.
<b>Fabrication and Installation</b>	Contractor to provide shop drawings based on approved Construction Certificate drawings for acceptance by Council’s Project Officer.
<b>Standard Drawing Reference</b>	LSD-MO-CS Morisset Custom Seat

### Seats - Guidance on design and specifying

<b>Positioning</b>	<ul style="list-style-type: none"> <li>If located adjacent vehicle parking areas, position seats with sufficient clearances to avoid conflict with opening car doors.</li> <li>Typically orient seats to be parallel to the kerb.</li> <li>Ensure there is a minimum 500mm clearance between the edge of the seat and any accessible path of travel.</li> <li>In areas of high use by people with ambulatory disabilities, such as areas frequented by elderly people, provide seats compliant with AS1428.2 at no more than 60 m apart alongside paths of travel.</li> <li>On sloping sites, design level pads to accommodate seating</li> <li>Allow sufficient clearance to maintain clear paths of travel for circulation around the seat installation, including for maintenance cleaning.</li> </ul>
<b>Equal Access</b>	<ul style="list-style-type: none"> <li>A variety of seating options should be provided in Town Centres to cater for people of varied abilities. Where a variety of seating is proposed, ensure a minimum of one seating option complies with the requirements of AS1428.2 – Design for Access and Mobility.</li> <li>There shall be 1800mm minimum accessible path of travel where the footpath adjoins building facades and property boundaries. Ensure seats – including leg room when seats are occupied- does not encroach into this accessible path of travel</li> <li>Seats installed adjacent to public access ways they should provide a minimum 30% colour contrast to the background pavement, wall, fence or vertical surface to enhance detection by people with low vision.</li> <li>Seats located in public domain plazas should not be placed where pedestrians could be expected to walk, on desire lines or in areas of heavy pedestrian traffic. If the seats are not set back from primary pedestrian access ways then hazard warning tactile ground surface indicators should be installed, in accordance with AS 1428.4.1.</li> </ul>
<b>Digital Connectivity</b>	<ul style="list-style-type: none"> <li>Consider where digital technology is appropriate to the function of a space. Generally this will be located in public domain plazas, nodes and key places where benefit will be derived from smart technology.</li> <li>Locate and provide in accordance with Lake Macquarie: The Smart City Guidelines for Integrating Emerging Technology into the Built Environment.</li> </ul>
<b>Environmental Sustainability</b>	<ul style="list-style-type: none"> <li>The serviceable life span of public seating should be maximised through: <ul style="list-style-type: none"> <li>design to minimise corrosion and vandalism opportunities;</li> <li>construction from robust materials;</li> <li>Installation in accordance with approved project documentation.</li> <li>Installation to enable product re-location and re-use.</li> </ul> </li> </ul>
<b>Performance Criteria</b>	<ul style="list-style-type: none"> <li>Shall be constructed from robust materials fit for purpose.</li> <li>Shall be constructed from materials, and/or have finishes and coatings, that provide ease of cleaning and graffiti removal.</li> <li>Shall be free from sharp edges and projections.</li> <li>The height of seats to be in the range of 400- 500mm above the finished pavement level.</li> <li>The width of the bench from edge of seat to front of backrest is to be in the range of 400-450mm.</li> <li>Provide armrests to both ends of seat. The height of armrests above the seat to be in the range of 220-300mm.</li> </ul>
<b>Relevant Standards and Codes</b>	<p>Austrroads GUIDE TO ROAD DESIGN PART 6B: ROADSIDE ENVIRONMENT  Austrroads GUIDE TO ROAD DESIGN PART 6A: PEDESTRIAN AND CYCLIST PATHS  AS1428 Design for Access and Mobility Suite  Lake Macquarie: The Smart City Guidelines for Integrating Emerging Technology into the Built Environment.</p>

## **12.0 MORISSET CUSTOM DETAILS**

**LSD-MO-CTG MORISSET CUSTOM TREE GUARD**

**LSD-MO-CS MORISSET CUSTOM SEAT**

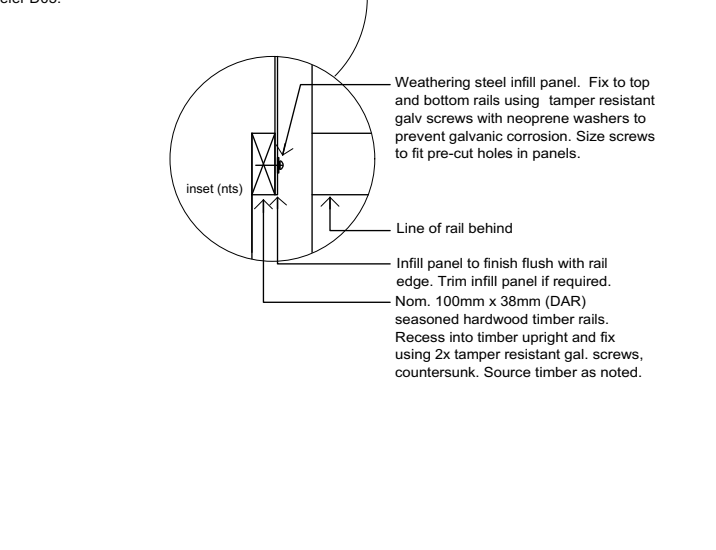
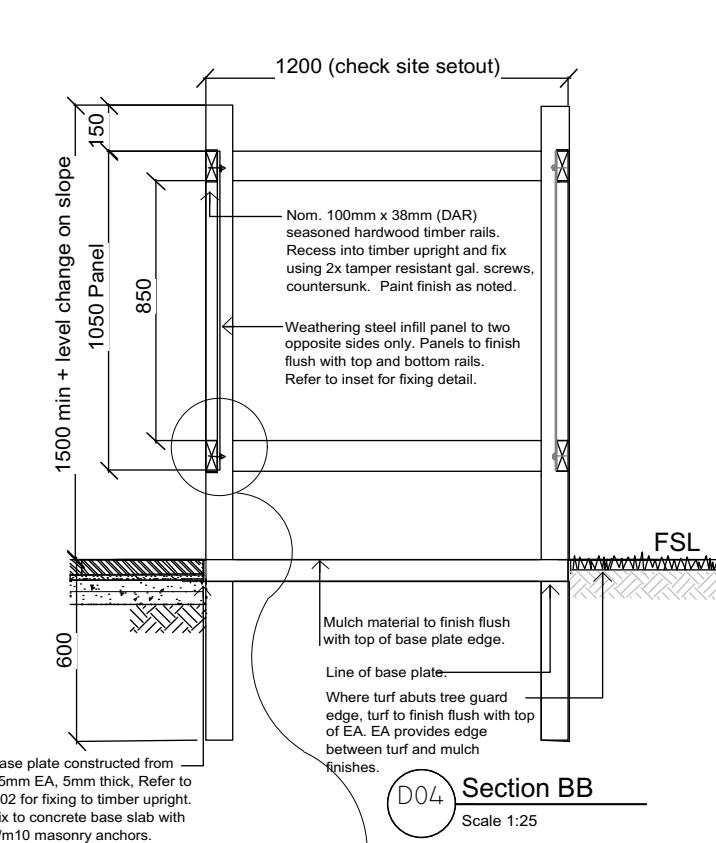
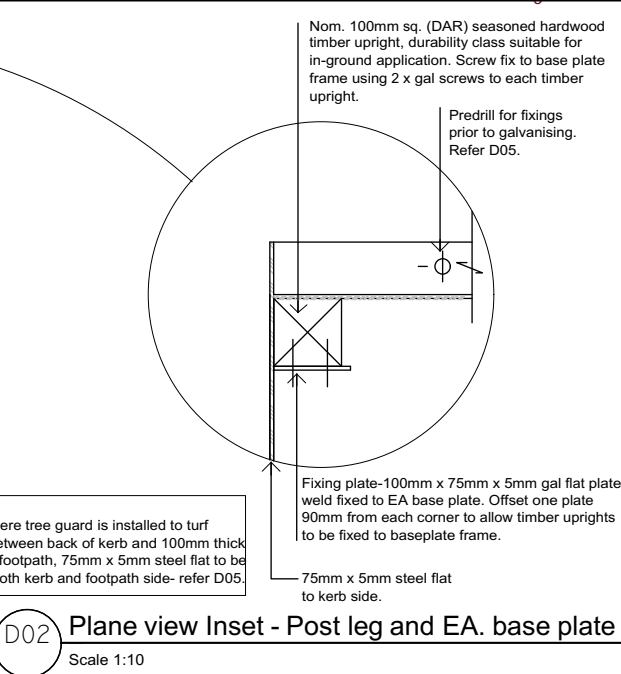
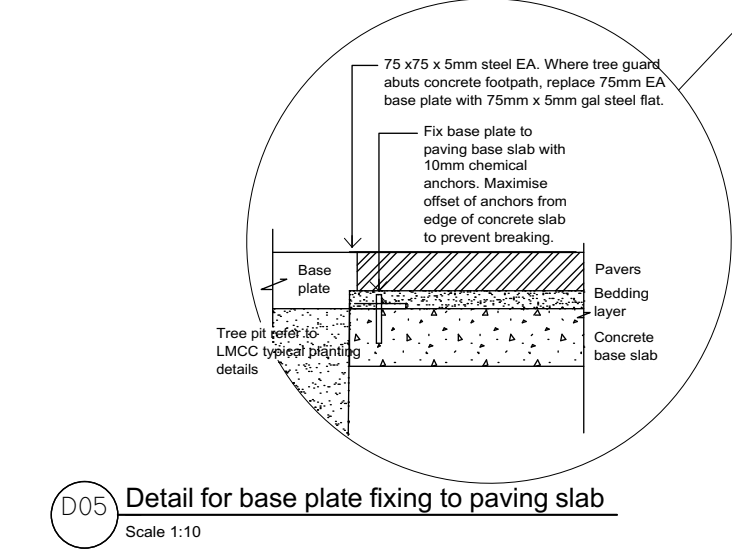
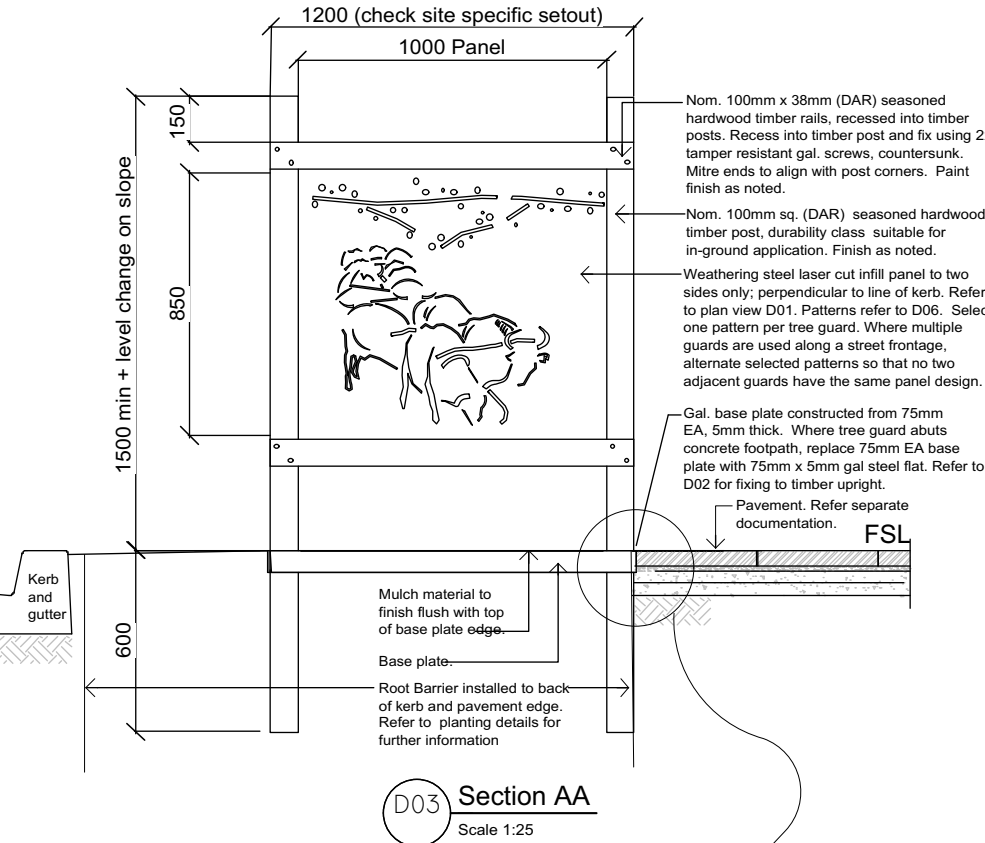
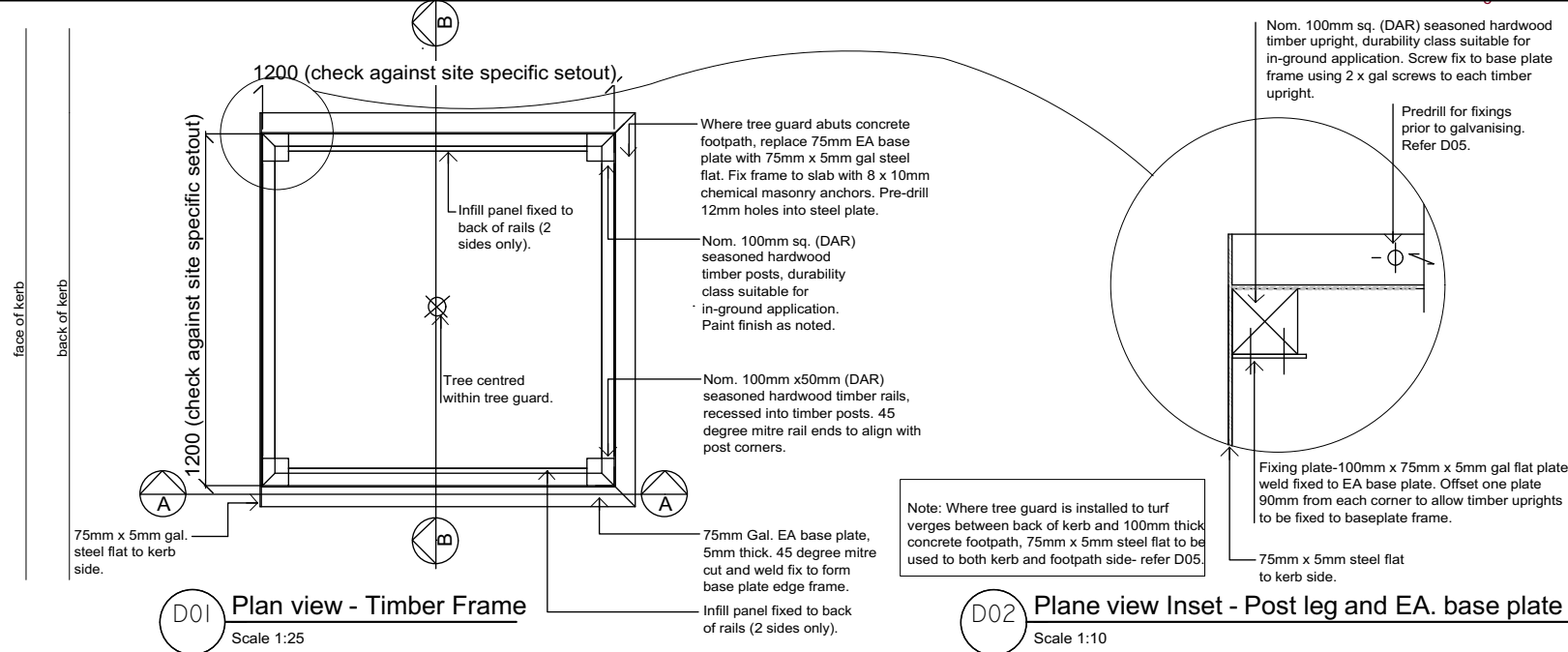

- NOTES**
1. Do not scale off drawings. Dimensions take precedence over scale measurements.
  2. Preorder H4 posts to ensure availability in sizes required.
  3. For trees in paving, ensure that tree guard widths correspond to the tree pit opening allowed for in the paving design. Check on site prior to installation to ensure tree guards and pit widths are consistent.
  4. All mild steel components shall be hot dip galvanised. Carry out all welding, grinding and drilling for fixings prior to hot dip galvanising.
  5. Ensure all galv tamper proof screws used to fix weathering steel infill panels to rails are installed with neoprene washers to prevent galvanic corrosion.
  6. Refer to Morisset Streetscape Technical Guidelines - Planting - Tree Guards for timber finish.
  7. Contact LMCC City Design on 49210234 for CAD file of laser cutting pattern. Adjust pattern as required to suit site specific dimensions. The contractor shall check that patterns are current for each project. Do not use previously supplied files unless specifically directed in writing by LMCC City Design.

<b>FOR INCLUSION IN MORISSET STREETScape TECHNICAL GUIDELINES</b>			
VER	DATE	COMMENTS	APPD BY
A	16/4/18		
SCALE: <b>AS NOTED</b>			
HEIGHT DATUM:	COORDINATES:	ORIG. SHEET SIZE:	
AHD	-	A3	
DRAWN BY:			
DESIGNED BY:			
SURVEYED BY:			
WORK TO FIGURED DIMENSIONS - DO NOT SCALE. CHECK DIMENSIONS AND LEVELS ON JOB BEFORE ORDERING MATERIALS OR COMMENCING WORK. THIS DRAWING IS SUBJECT TO COPYRIGHT AND IS THE PROPERTY OF LAKE MACQUARIE CITY COUNCIL. DO NOT RETAIN, COPY OR USE WITHOUT THE WRITTEN PERMISSION OF CITY DESIGN.			
THIS DRAWING IS AN UNCONTROLLED COPY UNLESS STATED OTHERWISE			
PREPARED BY:			
126-138 MAIN ROAD PH: 02 4921 0333 SPEERS POINT FAX: 02 4958 7257			
PROJECT NAME: <b>MORISSET CUSTOM DETAILS STREETScape TECHNICAL GUIDELINES</b>			
PROJECT ADDRESS AND DETAILS: <b>MORISSET TOWN CENTRE</b>			
DRAWING TITLE: <b>LSD-MO-CTG Morisset Custom Tree Guard</b>			
FOLDER NO.:	CAD FILES:		
PM13/0213/04/02	Morisset Custom details		
DRAWING NO.:	VERSION:	REVISION:	SHEET:
1 OF 1	CONCEPT		1

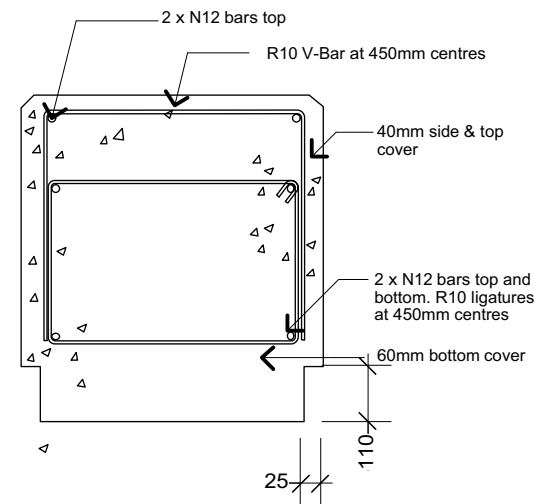
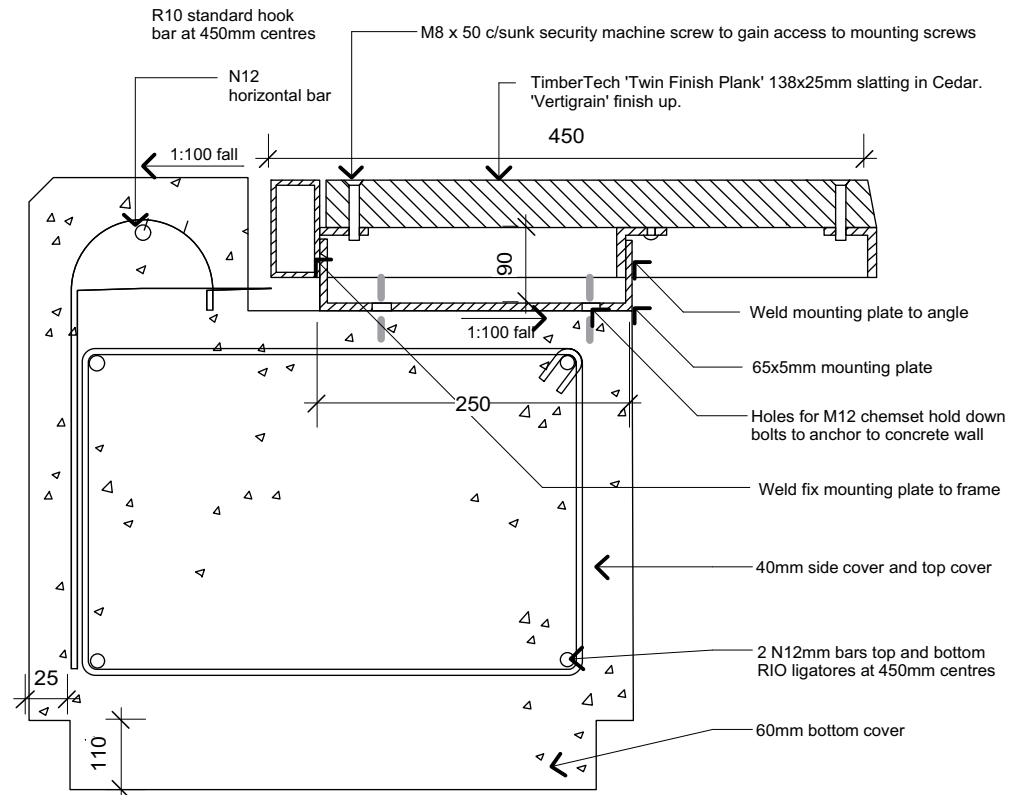
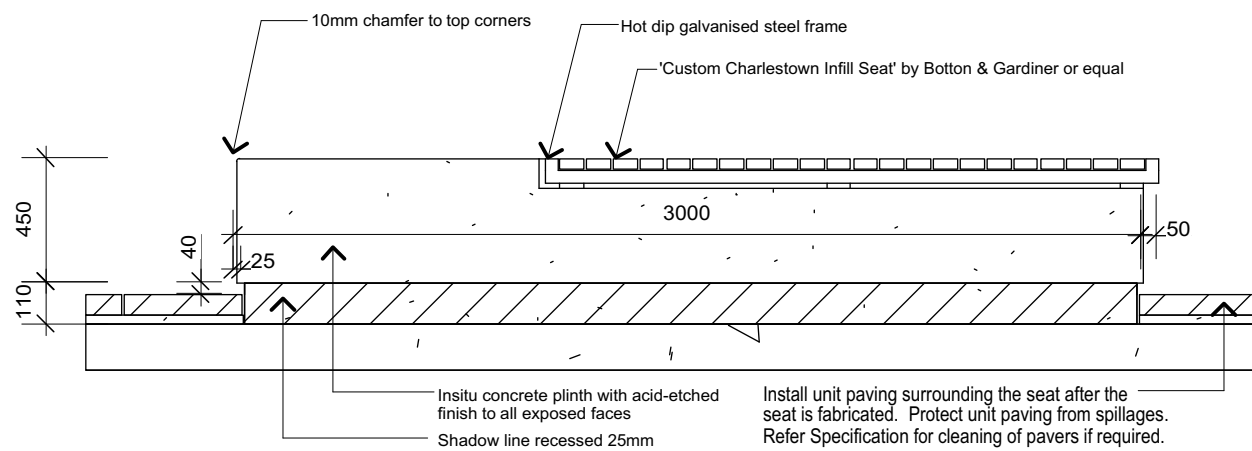
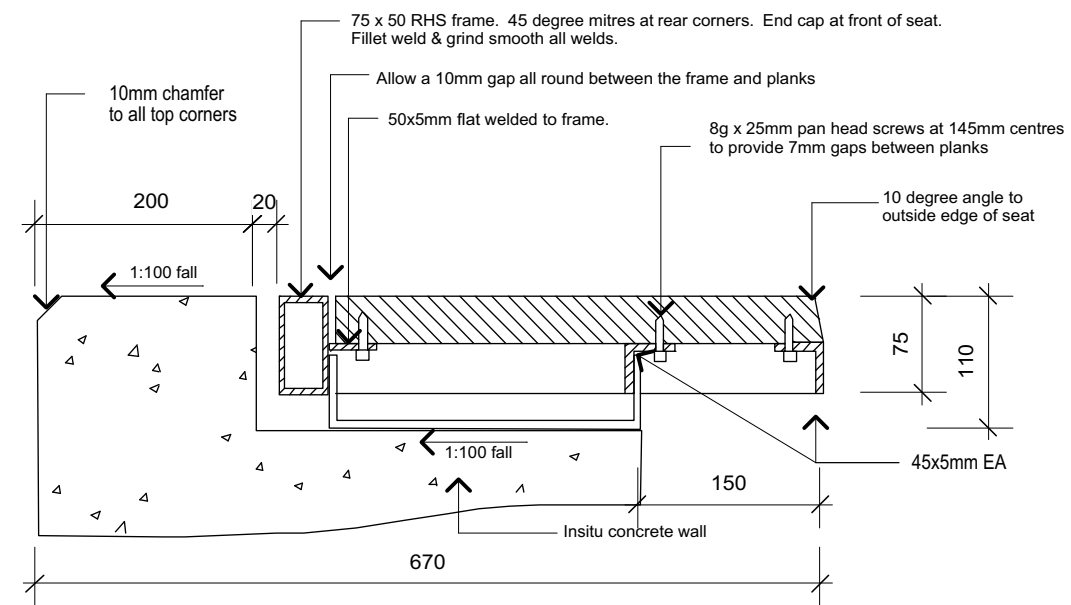
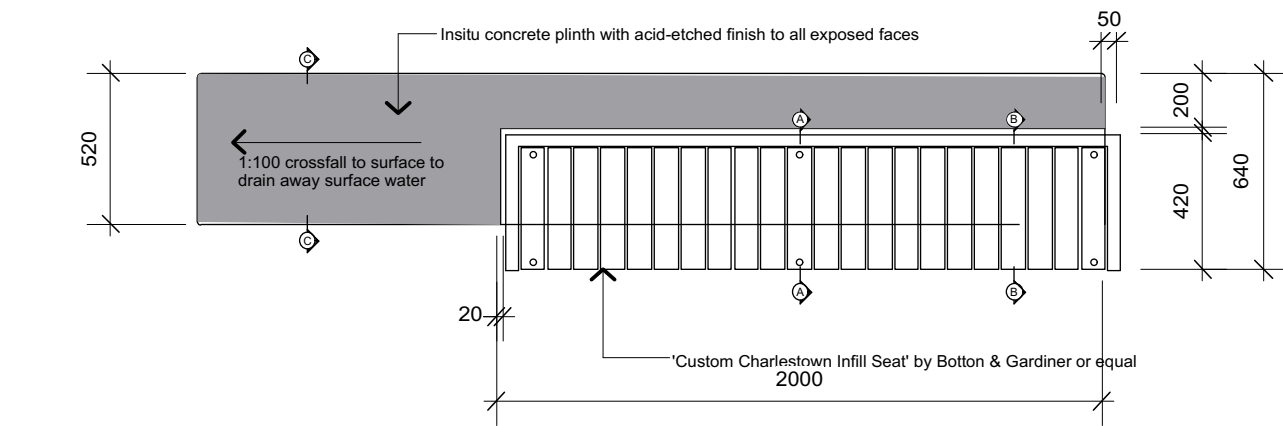

**SPECIFICATION**

**GENERAL:** The reinforcement design is for concrete poured insitu. Concrete works may be undertaken as a precast off site however where off-site pre-cast is proposed, consult with an engineer requiring reinforcement requirements for transport and lifting. Consideration shall also be given to access & traffic issues for lifting & positioning. To protect unit paving finishes, install paving after completing custom seats. Ensure any spillages or discolouration to paving is cleaned using an acid wash applied with an oscillating brush by a contractor experienced with clean eg. graffiti removal contractor. Do not attempt to clean pavers in other ways.

**CONCRETE:** Strength, nominally to a minimum of 32 MPa compliant with AS 3600. Mix shall be 60% 10-25mm grade Nepean River Gravel and 40% 10-mm blue Metal using yellow Sydney sand and Portland grey cement. Length of concrete plinth to vary to suit Infill seat length. Maintain same proportions (ie. Infill Seat shall be two thirds the length of the concrete plinth).

**BASE:** Install footings on 75mm consolidated thickness of fine crushed rock compacted to 95% medium dry density and graded to falls. Ensure level base to provide a level finished seat surface.

**REINFORCEMENT:** Note: Reinforcement has been designed for insitu construction on either a concrete or gravel base.

**FINISHING:** Provide a Class 2 (to comply with AS 3610) in situ concrete with smooth - acid etched finish to all exposed faces. Achieve acid etched finish by casting concrete against a smooth form. After removal from the form allow the element to set to a uniform hardness. Wash the concrete with an acid solution and scrub to remove the cement surface to a level, smooth and sand textured surface. Implement environmental controls to contain acid wash.

**SEAT INFILL:** 'Charlestown Custom Infill Seat' by Botton and Gardiner or equal as detailed. 1m, 2m and 3m lengths can be custom made to suit seat variations.

**STEEL FABRICATION:** All steel fabrication to hot dip galvanised. Drill venting holes to underside of tube to allow for venting. Pre-drill fixing holes, weld & grind smooth all joints prior to hot dip galvanising.

FOR INCLUSION IN MORISSET  
STREETSCAPE TECHNICAL  
GUIDELINES

VER: 16/4/18 DATE: COMMENTS: APPD BY:

SCALE: N/A

HEIGHT DATUM: AHD COORDINATES: ORIG. SHEET SIZE: A3

DRAWN BY: CC  
DESIGNED BY:  
SURVEYED BY:

WORK TO FIGURED DIMENSIONS - DO NOT SCALE. CHECK DIMENSIONS AND LEVELS ON JOB BEFORE ORDERING MATERIALS OR COMMENCING WORK. THIS DRAWING IS SUBJECT TO COPYRIGHT AND IS THE PROPERTY OF LAKE MACQUARIE CITY COUNCIL. DO NOT RETAIN, COPY OR USE WITHOUT THE WRITTEN PERMISSION OF CITY DESIGN.

THIS DRAWING IS AN UNCONTROLLED COPY UNLESS STATED OTHERWISE

PREPARED BY:



126-138 MAIN ROAD PH: 02 4921 0333  
SPEERS POINT FAX: 02 4958 7257

PROJECT NAME:  
**MORISSET CUSTOM DETAILS  
STREETSCAPE TECHNICAL GUIDELINES**

PROJECT ADDRESS AND DETAILS:  
**MORISSET TOWN CENTRE**

DRAWING TITLE:  
**LSD-MO-CS Morisset Custom Seat**

FOLDER NO.: PM13/0213/04/02  
DRAWING NO.: 1/1

CAD FILES:  
**Morisset Custom details**  
VERSION: CONCEPT REVISION: SHEET: L01